

Slewing Bearing Catalog



Company Profile

LYC is the largest bearing manufacturer in China. Its product range covers over 6,000 sizes in 9 categories and are available in every precision tolerance class. The products OD size range varies from 10mm up to a maximum 5.44 meters, bearing weights range from 25.4 grams up to 15 tons, the annual manufactured volume output is in excess of 70 million pieces.

LYC bearings have been, and continue to be successfully used in many and varied applications some of the following are but a few of the typical applications: Automotive, Mining Industry, Steel Industry, Petrochemicals, Power Generation Industry, Trucks, Agricultural Machinery, Textile Industry, Railways, Ships, Aviation and Space Flight.



Aerial view of the LYC facility in Luoyang

LYC's Technology and Design Center have designed, developed and produced prototypes for every imaginable application. This center works closely with their customers' so as to ensure their demands in efficiency, performance, life expectancy, and cost effectiveness are all met.

LYC's reputation is based on the Quality and Competitiveness of its products. In order to be internationally recognized for their quality the Luoyang Bearing Corp (Group) have gained and continue to maintain their ISO 9001 status. Additionally LYC's 6 subsidiaries have attained the ISO 9002 status and the Automotive Division has also been awarded ISO 9000 (VDA6.1 & ISO/TS16949)

Content



Introduction to slewing bearings	4 – 5
Slewing ring application.....	6
Part number designation for slewing rings.....	7
Materials & Internal clearance	8
Packaging / Lubrication & Seals	9
Installation	11
Maintenance.....	12
Calculations for the type & selection of slewing bearings.....	13
Load curve calculations for a slewing bearing.....	13
Tables & formula for load calculation of slewing bearings.....	14
Load factor & service life for the selection of bearings.....	15
Method of calculating service life.....	16
Selection calculation example 1	17 – 18
Selection calculation example 2	18 – 19
LYC SR Application Dynamics Questionnaire	20
Contact information	21
Slewing bearing dimensional information	22 – 43



INTRODUCTION TO SLEWING BEARINGS

The multiple-varied designs and use of specialty steels currently available today has allowed LYC to provide industry and commerce with the ability to increase loading capacities, reduce size and extend life expectancy beyond previously used Slewing Bearing designs. These bearing designs and their application must take into account a number of complex dynamic forces e.g.: Axial/Thrust Loads, High Radial Loads, and Moment Loads. Today's Slewing Bearings are used in some of the following industries and applications: Construction Industry, Excavation Industry, Wind Turbines, Medical Equipment, Radar, Military Applications, Rail/Transit Industry and Oil industry to name but a few.

There are a number of basic designs that are best suited to individual applications, these can often be adapted by a mixture of categories to optimize performance, improve reliability and provide the most cost effective, efficient solution. The following are some categories available today: Four and Eight Point Contact Ball, Three Row Roller, Bi-angular Roller and Taper designs. Drives are provided by inner or outer gear-drive, or driven directly by the inner or outer-ring.



FOUR-POINT CONTACT BALL

Four-point contact ball bearings are suited to axial, radial, and moment loads. The four point contact is distributed between the balls and the two split raceways. The precision grinding and geometry of the ball and deep groove raceway allow for the application of increased thrust and moment capacity. Typical applications for these bearings are: Machine Tools, Radar, Medical Equipment and Construction Equipment. Sizes range from 260mm to 4850mm.

THREE ROLLER CONFIGURATION

These designs provide for the highest load rating of all designs. The three roller configurations allow for the two rollers in the vertical axis to take both axial and moment loads from the two adjacent raceways, whilst the third roller facilitates the radial load. Typical applications for these designs are in Construction, Opencast Mining and Marine applications.



DOUBLE-ROW ANGULAR CONTACT THRUST BALL

The eight point contact bearing design in principal is the same as the four point contact bearing with an additional ball and raceway configuration placed adjacent in the vertical axis's, this allows for loading to be evenly distributed between the two raceway arrangements, this configuration will allow for an increase in loading capacity of between 75 - 80% as opposed to the four point contact bearing, with additional dynamic forces being made available of up to 50% (approximately).

SINGLE CROSSOVER (BI-ANGULAR) ROLLER CYLINDRICAL OR TAPER

The roller and raceway orientation are positioned at 45 degrees to the axis. The static loading capacities for these designs relative to the roller surface contact area are superior as opposed to the four and eight point contact bearings, additionally; the rigidity in this design allows for higher rotational speeds and will allow for a greater degree of misalignment in mounting. However, radial thrust limitations are less than that of the four and eight point contact bearing design.



SLEWING RING APPLICATION

*Taking into account the complexity in slewing ring and table bearing applications the following should be given careful consideration: fixed static loads, speed, accuracy, friction torque, seals, lubrication, mounting, size limitations and variables in axial, radial, and moment loads. Additional technical consideration should be provided to gear drive and ratio, its location either inner or outer location (if required). LYC highly recommend that customers contact the **LYC SR Division Technical Department** to confirm any calculations they may have conducted themselves before selecting a LYC slewing ring. LYC have inserted a **SR Application Dynamics Questionnaire** (Page 20); this questionnaire will allow the **LYC SR Div Technical Department** to provide their customers with the “Best Fit Solution” for their application.*



PART NUMBER DESIGNATION

Due to the complexity and variation in design of slewing bearings LYC have adopted two differing representations in-order to provide meaning to their part numbers, detailed opposite in Representation 1 are the prefix's for the construction of the part number, these identify the bearings design, the numbers following this prefix identify the following information: number of rolling elements, raceway structure, form and gear mesh mode, rolling element diameter, rolling element center circle diameter, material, and roughcast form. These are further explained in Representation 2 below.



Bearings for wind energy generator



Split bearings



Slewing bearings



Insulated bearings



High precision bearings for rolling mill

REPRESENTATION 1:

TYPE AND CONFIGURATION	TYPE WITHOUT GEAR	TYPE WITH OUTER GEAR	TYPE WITH INNER GEAR
Four-point contact ball slewing bearing	78000	178000	278000
Double row angular contact thrust ball slewing bearing	578000	678000	778000
Cross cylindrical roller slewing bearing	79000	179000	279000
Cross tapered roller slewing bearing	579000	679000	779000
Three row cylindrical roller combined slewing bearing	539000	639000	739000

REPRESENTATION 2:

The construction of the LYC slewing bearing part number is identified below; these part numbers are segmented into four numeric units, with the first segment containing three sub-sections.

$$\frac{\times}{1} \frac{\times}{2} \frac{\times}{3} . \frac{\times \times}{4} . \frac{\times \times \times \times}{5} . \frac{\times \times}{6}$$

1. Type of rolling element: 0—ball 1—roller
2. Raceway structure form:
 - 1—four-point contact ball form or cross-cylindrical roller form
 - 2—eight-point contact ball form or cross tapered roller form
 - 3—three-row cylindrical roller form
3. Gear mesh form: 0—no gear; 1—external gear with small module; 2—external gear with large module; 3—internal gear with small module; 4—internal gear with large module;
4. Diameter of rolling element (mm)
5. Center circle diameter of rolling element (mm)
6. Material and provided state of roughcast

RINGS AND ROLLING ELEMENT

Generally slewing bearing rings and their rolling elements are manufactured from through-hardening alloys (GCr15 or GCr15SiMn) these are equivalent to the AISI-SAE 52100 or E52100 family of alloys. LYC can provide additional material specifications, dependent on their customer's requests. Additional materials that can be used are 50Mn (equivalent to AISI C1050 OR SAE 1052), 42CrMo (equivalent to AISI-SAE 4140) or 5CrMnMo (equivalent to AISI-SAE V1G)

Table 3 Axial Clearance In Four-Point Contact Ball Slewing Bearings μm

Dpw		Tolerance Classes					
		G		E		D	
mm		Axial Clearance					
Over	Incl	Min	Max	Min	Max	Min	Max
280	450	70	170	50	130	30	90
450	710	100	220	70	170	40	120
710	1120	120	280	100	220	50	150
1120	1800	150	350	100	260	60	180
1800	2800	200	440	150	350	80	240
2800	4500	260	540	200	440	100	300

Table 5 Crossed Cylindrical Roller Slewing Bearings μm

Dpw		Tolerance Classes					
		G		E		D	
mm		Axial Internal Clearance					
Over	Incl	Min	Max	Min	Max	Min	Max
280	450	50	130	30	90	25	70
450	710	70	170	40	120	30	90
710	1120	100	220	50	150	40	120
1120	1800	100	260	60	180	40	140
1800	2800	150	350	80	240	60	180
2800	4500	200	440	100	300	80	240

INTERNAL CLEARANCE

In order to ensure that Slewing Bearings operate smoothly they are set with an internal clearance, this clearance also accommodates for some degree of distortion within the mounting frame structures, these clearances vary depending on size, type, and grade classification of the bearing. These clearances are shown in the Tables below 3 – 6.

Table 4 Two-row Angular Contact Thrust Ball Slewing Bearings μm

Dpw		Tolerance Classes					
		G		E		D	
mm		Axial Internal Clearance					
Over	Incl	Min	Max	Min	Max	Min	Max
280	450	50	130	30	90	25	70
450	710	70	170	40	120	30	90
710	1120	100	220	50	150	40	120
1120	1800	100	260	60	180	40	140
1800	2800	150	350	80	240	60	180
2800	4500	200	440	100	300	80	240

Table 6 Three-row Cylindrical Roller Combination Slewing Bearings μm

Dpw		Tolerance Classes											
		G				E				D			
mm		Axial		Radial		Axial		Radial		Axial		Radial	
Over	Incl	Min	Max	Min	Max	Min	Max	Min	Max	Min	Max	Min	Max
280	450	30	90	50	130	25	70	30	90	10	50	25	70
450	710	40	120	70	170	30	90	40	120	15	65	30	90
710	1120	50	150	100	220	40	120	50	150	20	80	40	120
1120	1800	60	180	100	260	40	140	60	180	20	100	40	140
1800	2800	80	240	150	350	60	180	80	240	30	130	60	180
2800	4500	100	300	200	440	80	240	100	300	40	160	80	240

PACKING AND STORAGE

All LYC slewing bearings leave their factory with rust inhibitor lubricant coatings on both the inner and outer surfaces. Bearings are generally Kraft paper wrapped, with larger bearings have an additional Poly-wrap seal. Individual wooden packaging is manufactured for larger bearings, these packaging systems allow for easier transportation, handling and storage.

Bearings should be stored in a clean, dry and chemical free environment, (not outside). They should be well supported preferably on a flat surface in the horizontal position, if several bearings of equal size are to be stored they should be stacked, again, in the horizontal position with equal in size dividing blocks at a minimum 120 degrees around the top and bottom of the corresponding surfaces of each bearing. These bearings can be stored for up to 12 months from the date of manufacture without any additional maintenance. For bearings that remain in storage over 12 months these should have their grease and rust preventative coatings removed, once cleaned these surfaces should be re-coated and the bearing re-greased, LYC recommend that guidance should be sought from LYC in order to carry out this storage maintenance task, should it be required.

LUBRICATION AND SEALS

In order to ensure that bearings perform inline with specifications and customer requirements they are generally greased prior to delivery to the customer with one of the greases identified in Table 7, unless otherwise specified by the customer to be only lightly lubed. The choice of grease can also be a critical item in the design and performance criteria, consideration should be provided to the bearings working environment, some of these considerations are: speed, temperature, pressure and the possibility of contamination ingress. The most common greases used today for general applications are Calcium or Lithium soap based greases, with Aluminum based grease being used in higher temperature applications..

Seals play another important part in the bearings ability to perform correctly and aid in its reliability and longevity during its service life. The prime objective of these mechanisms is to ensure that contaminants e.g.: water or any type of dust particles are not allowed to enter the rolling elements or their corresponding raceways, and retain lubrication. Generally Nitrile seals are used; however, Labyrinth, Nylon, or Teflon configurations can be applied for even more effective sealing solutions. The selection of a particular sealing solution, in many respects, is focused on the bearings working environment.

Most influential bearing brand in China

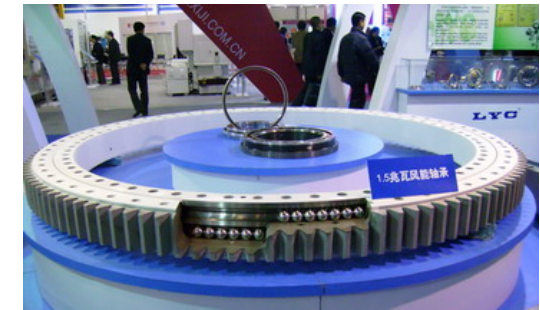

Table 7: Lubrication and seals

Structure and seals style	Working Condition		Lubrication Position	Lubrication Grease	
				Description	Name
Massively, segmented cage or plastic partition	low temperature , normal temperature,	-40 ℃-- +60 ℃	Raceway	calcium lubrication grease	ZG--3
					ZG--4
					ZG--5
Rubber seals	dampness;		Gear	blacklead calcium lubrication grease	ZG--S
Multilayer partitions	high temperature,	40 ℃-- 140 ℃	Raceway	lithium lubrication grease	ZL-1
					ZL-2
					MoS2 complex calcium lubrication grease
Labyrinth type seal	dampness	80 ℃-- 180 ℃	Raceway	MoS2 complex calcium lubrication grease	NO,2
			Gear	No.4 high temperature lubrication grease	ZN6-4
		normal temperature, corrosionproof 50 ℃	Raceway	No.2 lithium lubrication grease	ZU-2
			Gear	No.2 lithium lubrication grease	ZU-2

INSTALLATION AND MAINTENANCE

LYC take great care in producing slewing bearings for their customers, these rings, balls & rollers are precision bearing components, it is important that the assembler take care to install these bearings inline with the manufacturer's instructions, in order to ensure efficient and effective operation of their customer's equipment. Prior to installation a close inspection should be performed so as to ensure that upper and lower mounting surfaces are flat level and parallel to each other (see Table & Graph opposite), these surfaces should be paint free, free from indentations, burrs or any other contaminant that could cause distortion or misalignment between the inner and outer ring when mounted to their corresponding surfaces. The surfaces themselves should have sufficient hardness and have such a structure so as to avoid distortion or deflection when the bearing is under load. Table 8 opposite provides clear indication as to the acceptance criteria for mounting surfaces for these types of bearings. The bearing should be brought into position by either firmly secured eyebolts or nylon strops, in both cases a minimum of three supports should be applied. The LYC slewing bearing has a soft zone marked with an "S" on the outer-ring; this location is in direct line with the load-hole plug, it is important that this area is located at 90 degrees to the major load zone. In order to ensure that the bearing is operating with minimum torque install the lock down bolts but do not tighten, measure this torque value over 360 degrees so as to ensure correct alignment for both inner and outer ring, also any pinion gear drive that may apply. Providing these resistances are acceptable then the lock down may begin in the transverse directional manner, prior to this lock down there should be enough pre-load applied to equal 70% of the field limit. Bolts should be torqued in accordance with their size, grade and bolt manufacturers specification, Table 9 shows an indication as to these recommended values, the use of any type of lock washer is prohibited from any slewing ring installations.

Table 8 Technical Specifications for Bearing Surface

Center hole diameter D1 or D2 mm	Flatness α			Deviation of inclination pitch with same direction on circle adjacent unit length ($L = a$ row pitch)			Deviation of inclination pitch with same direction on circle adjacent unit length ($L = a$ row pitch)			Inclination pitch of radial width b			Surface roughness R_a		
PRECISION CLASS															
OVER TO	G	E	D	G	E	D	G	E	D	G	E	D	G	E	D
250 400	120	80	50	0.0002L	0.00013L	0.00008L	0.0002L	0.00013L	0.00008L	60	40	25	2.5	1.25	0.8
400 630	150	100	60							80	50	30	2.5	12.5	0.8
630 1000	200	120	80							100	60	40	2.2	12.5	0.8
1000 1600	250	150	100							120	80	50	3.2	2.5	1.25
1600 2500	300	200	120							150	100	60	3.2	2.5	1.25
2500 4000	400	250	150	200	120	80	3.2	2.5	1.25						
4000 6300	500	300	200	250	150	100	3.2	2.5	1.25						

Flatness of working table surface

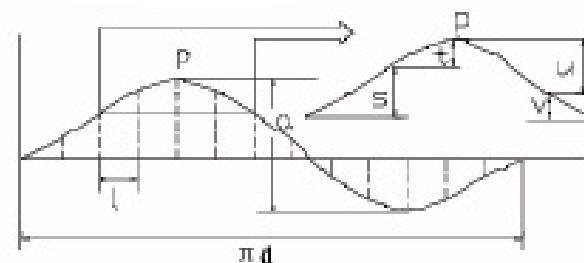

Circle Outspread

Gradient of working table surface on the radial width

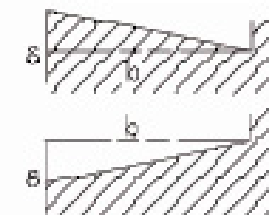

Table 9:

Strength class of bolt ISO898			8.8 M≤16 640			10.9 940			12.9 1100		
limit of yielding			M < 16 660								
N/mm ²											
Dia.	Stress area	Section area	Pre- tightening force	Theoreti- cal fas- tener moment	torque NM	Pre- tightening force	Theoreti- cal fas- tener moment	torque NM	Pre- tightening force	Theoreti- cal fas- tener moment	torque NM
M5	14.2	12.7	6400	6.1	5.5	9300	8.9	8	10900		
M6	20.1	17.9	9000	10.4	9.3	13200	15.5	13.9	15400	10.4	9.3
M8	36.6	32.8	16500	25	22.5	24200	37	33	28500	18	16.2
M10	58	52.3	26000	51	45	38500	75	67	45000	43	38
M12	84.3	76.2	38500	87	78	56000	120	117	66000	87	78
M14	115	105	53000	140	126	77000	205	184	90000	150	135
M16	157	144	72000	215	193	106000	310	279	124000	240	216
M18	193	175	91000	300	270	129000	430	387	151000	370	333
M20	245	225	117000	430	387	166000	620	558	194000	510	459
M22	303	282	146000	580	522	208000	830	747	243000	720	648
M24	353	324	168000	740	666	239000	1060	954	280000	970	873
M27	459	427	221000	1100	990	315000	1550	1395	370000	1240	1116
M30	561	519	270000	1500	1350	385000	2100	1890	450000	1850	1665
M33	694	647	335000			480000			560000	2500	2250
M36	817	759	395000			560000			660000		
M39	976	913	475000			670000			790000		
M42	1120	1045	542000	need bolt liquor		772000	need bolt liquor		904000	need bolt liquor	
M45	1300	1224	635000	straining device		905000	straining device		1059000	straining device	
M48	1470	1377	714000			1018000			1191000		
M52	1760	1652	857000			1221000			1429000		
M56	2030	1905	989000			1408000			1648000		
M60	2360	2227	1156000			1647000			1927000		

MAINTENANCE

In-order to ensure optimum performance and longevity of LYC slewing bearings in operation LYC recommend that after the first 100 hours of operation that the preload is checked and adjusted (if required) to the installation value. Re-lubrication should be applied preferably with the slow rotation of the bearing at the same time as injecting grease, in order to apply even distribution of the grease. Greasing should generally take place after 100 hours of operation, where the application is in fast turning equipment or in a continuous cycle operation then this re-greasing should take place after 8 hours of operation. If gears or pinion drives are integrated into these applications then this gearing should also be greased at these intervals. When these bearings are operating in extremely hostile conditions e.g.: extreme temperatures, excessively dusty environment or within a high moisture content environment then it is recommended that greasing intervals be closely reviewed, the **LYC SR Technical Department** will advise their customers on such issues as this. Automatic Greasing systems can be applied to these Bearings; however, this does not eliminate the visual inspections and bolt/mounting tension checks that are required periodically.

CALCULATIONS FOR THE TYPE & SELECTION

Unlike most other bearing applications slewing bearings are quiet often found to be working under extremely arduous conditions, typically misalignment (tilting), moment and impact loads are experienced regularly if not continually. Other factors to take into consideration are the physical constraints, circumferential forces that are incurred by any gear transmission. The previous and following sections in this catalog are only to serve as a guide towards a general understanding of the principals of slewing bearings. As mentioned previously LYC suggest that customers use the **LYC SR Application Dynamics Questionnaire**. Working with the content of these questionnaires and collaboration directly with the customer allows LYC to propose the most economical and **“Best Fit Solution”** for their customers.

LOAD CURVE CALCULATIONS

In order to understand the dynamics of applied forces and the bearings theoretical limitations during an operational mode LYC use well proven international formulas to show their bearings performance and limitations, much of this input data is initially extracted from the **SR Application Dynamics Questionnaire**. This input data can be used in a number of different models in order to find the **“Best Fit Solution”** The results of these load and service life curves etc provide a good understanding for the customer as to what they can expect from their bearing selection.

The load Curve Calculations shown opposite are for slewing bearings and are based on bearings being manufactured from 42CrMo, the allowance for the contact stress of these balls in this bearing are 3850Mpa, whilst that of the roller bearing is 2700Mpa. Curve 2 shows the carrying curve of the dynamic load rating with 90% reliability at 0.03×10^6 revolutions. Curve 3 shows the carrying curve of an allowed dead load when the slewing bearing is manufactured from 50Mn, the allowed contact stress for these balls within this bearing is 3400Mpa, whilst that of roller bearing would be 2100Mpa. The limiting load curve of a bolt is confirmed when the connected length is 4 times longer than the nominal diameter, and the pre-load is 70% of the yield limit of the bolt.

The load and bolt curve drawings shown in this catalog are only a small selection of the products currently available from LYC. If the part number you have selected does not have carrying curve drawing illustrated within this catalog then you should contact **LYC SR Technical Department** to obtain the carrying curve you require.

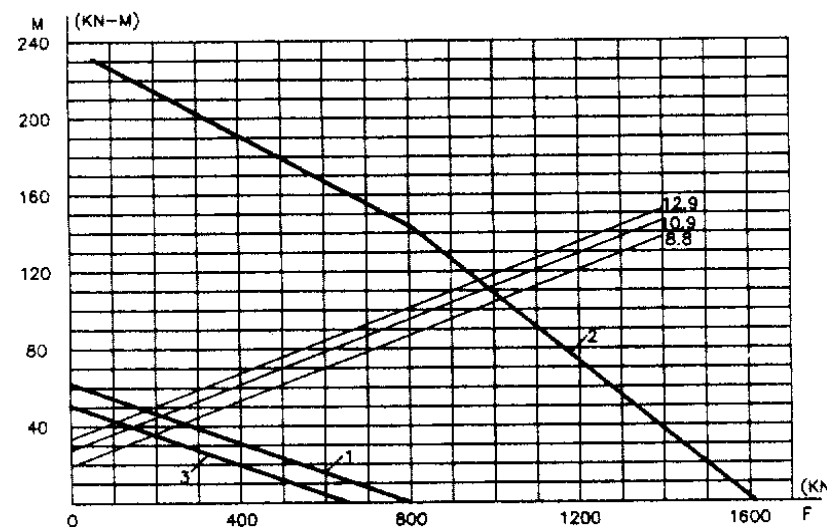

LOAD CURVE



Technical center

TABLES & FORMULA FOR LOAD CALCULATIONS

The tables below show the style/type of bearing with the static and dynamic load condition formula applied to obtain the load profile.

Table 10

Calculation Method Structure Type	Equivalent static load according to static working condition	Equivalent dynamic load of forecasting life according to dynamic condition
Four-point contact ball slewing bearing ($\alpha=45^\circ$)	When $Fr \leq 0.44 Fa$, $Fa' = (Fa + 2.3Fr) \cdot fs$ when $Fr > 0.44 Fa$, Please contact LYC's relevant department to obtain the calculation method of Fa' $M' = M \cdot fs$	When $Fr \geq 0.8 Fa$, $Fa' = (0.59 Fa + 1.18 Fr) \cdot fl$ when $Fr < 0.8 Fa$, $Fa' = (Fa + 0.66 Fr) \cdot fl$ $M' = M \cdot fl$
Double row angular contact thrust ball slewing bearing	when $Fr \leq 10\% Fa$, $Fa' = Fa \cdot fs$ when $Fr > 10\% Fa$, Please contact LYC's relevant department to obtain the calculation method of Fa' $M' = M \cdot fs$	when $Fr \leq 10\% Fa$, $Fa' = Fa \cdot fl$ when $Fr > 10\% Fa$, Please contact LYC's relevant department to obtain the calculation method of Fa' $M' = M \cdot fl$
Slewing bearing with crossed cylindrical roller ($\alpha=45^\circ$)	when $Fr \leq 0.44 Fa$, $Fa' = (Fa + 2.3Fr) \cdot fs$ when $Fr > 0.44 Fa$, Please contact LYC's relevant department to obtain the calculation method of Fa' $M' = M \cdot fs$	when $Fr \geq 0.67 Fa$, $Fa' = (0.67 Fa + 1.5 Fr) \cdot fl$ when $Fr < 0.67 Fa$, $Fa' = (Fa + Fr) \cdot fl$ $M' = M \cdot fl$
Three-row cylindrical roller combined slewing bearing	$Fa' = Fa \cdot Fs$ $M = M \cdot Fs$	$Fa' = Fa \cdot Fl$ $M' = M \cdot Fl$
	Radial load Fr is carried by a line of rollers beared radial load	



Extra-large wind energy bearing inspection

Where as:

- Fa = general axial load carried by bearing (KN)
- Fr = general radial load carried in the effective plane of moment by bearing (KN)
- M = general tilting moment carried by bearing (KN-m)
- Fa' = equivalent center axial load of bearing (KN)
- M' = equivalent tilting moment of bearing (KN-m)
- fs = safe index of static load
- fl = load index of forecast life

LOAD FACTOR & SERVICE LIFE FOR THE SELECTION OF BEARINGS

Similar to other bearing designs these slewing bearings are also provided with safety & load calculations, additionally there are calculated life expectancy values, understandably these life expectancy values are more often than not exceeded, as generally equipment is not fully loaded 100% of the time, where as the calculations include for a continual fully loaded state in the time element, these values are detailed opposite in Table 11

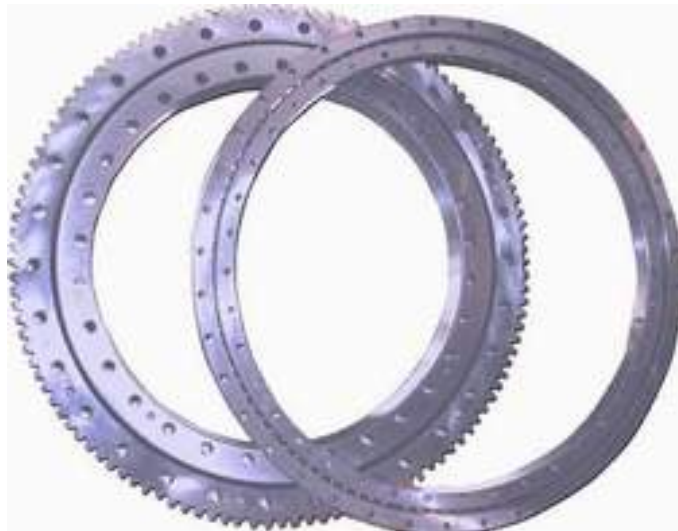

Table 11

			Static load safety factor f_s	Life load factor f_l	Service life at full load revolution L_f (revolution)
Ship crane, truck crane, grab board crane, revolving platform (continuously circulating required when running)			1.10	1.0	30000
Tower crane for construction application	Fixed on the tower	$M_f \leq 0.5M$	1.25	1.0	30000
		$0.5M < M_f < 0.8M$		1.15	45000
		$M_f \geq 0.8M$		1.25	60000
	Fixed on the base	1.0		30000	
Port frame crane, ship crane				1.15	45000
Metallurgical works crane				1.5	100000
Truck crane (grab or heavy duty manual) Rotary type crane (grab or cupula) Wheel crane (grab or cupula) Bridge crane (grab or cupula) Barge crane (grab or cupula)			1.45	1.7	150000
Cordage grab Stacker declaimer Goods conveyor				2.15	300000
Railway crane			1.0	Please contact LYC Technical Department when selecting bearings	
Small transporter			1.1		
Scraper			1.25		
Hydraulic development machine adopted four-point contact ball slewing bearing			1.25		
Adopt other type of slewing bearing, dipper capacity $< 1.5M^3$			1.45		
dipper capacity $\geq 1.5M^3$			1.75		
Ladle bogie			1.75		

Note: M_f is free load tilting moment of minimum work-

METHOD OF CALCULATING SERVICE LIFE

LYC use the bearings load curve to forecast the service life of the bearing in relationship to the related load factor, this service-life can be calculated as per the load curve with the following formula:

$L_f = (f_l)^\varepsilon \cdot 30000$ in the formula:

L_f = Service life of slewing bearing at full load (revolution).
 ε = Life factor.
 $\varepsilon = 3$ (Ball bearing).
 $\varepsilon = 10/3$ (Roller bearing).

$f_l = F_{ac} / F_{a'} = M_c / M'$ in the formula:

F_{ac} = Axial load of the cross point of the origin and the load point link line on the carrying curve KN.
 M_c = Tilting moment of the cross point of origin and load point link line on the carrying curve KN-m.

When slewing bearings are placed under fluctuating loads with variable cycle rates in their working time the calculation method that is applied is the average equivalent to the center axial load and the average equivalent of the tilting moment.

$$F_{a'} = (n_1 \cdot F_{a1}^\varepsilon + n_2 \cdot F_{a2}^\varepsilon + n_3 \cdot F_{a3}^\varepsilon + \dots + n_n \cdot F_{an}^\varepsilon)^{1/\varepsilon}$$

$$M' = (n_1 \cdot M_1^\varepsilon + n_2 \cdot M_2^\varepsilon + n_3 \cdot M_3^\varepsilon + \dots + n_n \cdot M_n^\varepsilon)^{1/\varepsilon}$$

Where as:

$n_1; n_2; n_3 \dots n_n$ = The percent of working time KN-m.
 $F_{a1}; F_{a2}; F_{a3} \dots F_{an}$ = Axial dynamic load within the percent of working time KN.
 $M_1; M_2; M_3 \dots M_n$ = Tilting moment within the percentage of working time of $n_1; n_2; n_3 \dots n_n$ KN-m

Average life: $L_f = 1 / (n_1/L_1 + n_2/L_2 + n_3/L_3 + \dots + n_n/L_n)$

In the formula: $L_1; L_2; L_3; L_n$ = Bearing life within the percentage of working time of $n_1; n_2; n_3 \dots n_n$ (revolution)



Selection Calculation and Example

Example1: A port frame crane is shown in figure 1 below, With a center of gyration is required to carry a load at 2.5m :

$Q=196.2\text{KN}$ $L_{max}=23\text{m}$
 $A=67\text{KN}$ $a_{max}=11\text{m}$
 $O=450\text{KN}$ $o=0.75\text{m}$
 $G=900\text{KN}$ $g=3\text{m}$
 $W=27\text{KN}$ $r=6.5\text{m}$

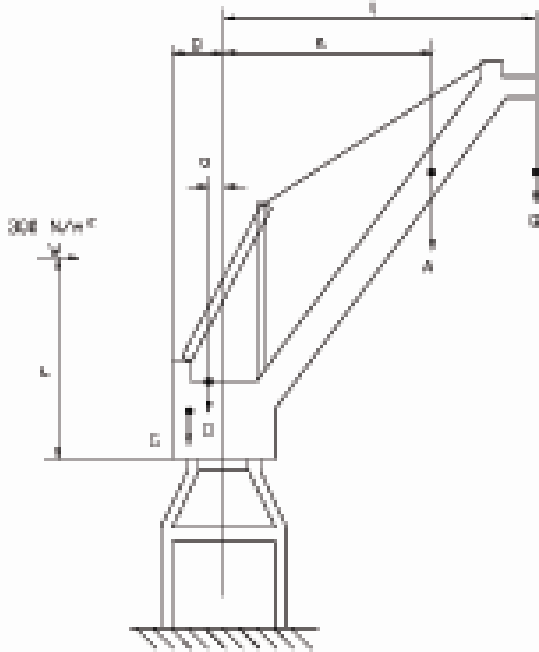

Figure 1

(1) The calculation below shows the result in the event the crane was overloaded by 25%

$$\begin{aligned}
 Fa' &= (Q * 1.25 + A + O + G + 2.3 + 2.3W) * fs \\
 &= (196.2 * 1.25 + 67 + 450 + 900 + 2.3 * 27) * 1.25 \\
 &= 2155.14\text{KN} \\
 M' &= (Q * 1.25 * L_{max} + A * a_{max} + W * r - O * o - G * g) * 1.25 \\
 &= (196.2 * 1.25 * 23 + 67 * 11 + 27 * 6.5 - 450 * 0.75 - 900 * 3) * 1.25 \\
 &= 4394.7 \text{ KN-m}
 \end{aligned}$$

(2) If the circumferential force on the bearing gear was $Ft = 375\text{KN}$, when the bearing is running then the calculation for the dynamic load would be as follows:

$$\begin{aligned}
 Fa' &= Q + A + O + G + 0.66Ft * \text{tg}20^\circ \\
 &= 196.2 + 67 + 450 + 900 + 0.66 * 375 * \text{tg}20^\circ \\
 &= 1703.3 \text{ KN} \\
 M' &= Q * L_{max} + A * a_{max} - O * o - G * g \\
 &= 196.2 * 23 + 67 * 11 - 450 * 0.75 - 900 * 3 \\
 &= 2212.1 \text{ KN-m}
 \end{aligned}$$

The calculation shows that a four-point contact ball slewing bearing with an internal gear 2789/2240 could be selected; this is identified below at the load curve points at curve 1 and curve 2 as shown in figure 2. Consequently the load requirement can be satisfied.

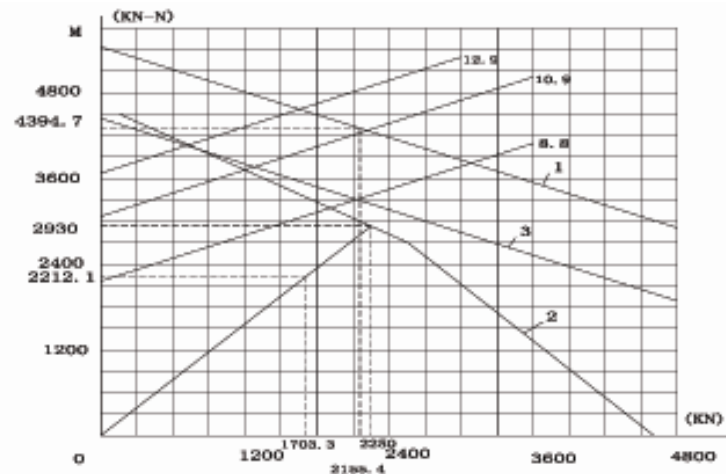

Figure 2 2789/2240 Slewing Bearing Load Curve

The axial load at the point of the intersection of the line connected by the load curve at the point of origin of dynamic load point and load curve 2 is $F_{ac} = 2250\text{KN}$; the tilting moment is $M_c = 2930\text{KN-m}$, the estimated bearing service life is:

$$f_l = F_{ac} / F_{a'} = 2250 / 1703.3 = 1.32$$

$$f_l = M_c / M' = 2930 / 2212.1 = 1.32$$

$$L_f = (1.32)^3 * 30000 = 69000 (\text{revolution})$$

In accordance with the requirement of Table 12.

Table 12

Load point	Working time %	The load carried by bearing		Load on the carrying curve	
		$F_{a'}$ KN	M' KN-m	F_{ac} KN	M_c KN-m
1	10	1600	4400	1900	5200
2	25	2400	4000	2750	4580
3	60	3200	2800	3900	3420
4	5	3600	5200	3050	4350

Example 2:

The LY-Q005 four-point contact ball slewing bearing, for which the load curve is showed in Figure 3 and the load chart shown in Table 12.

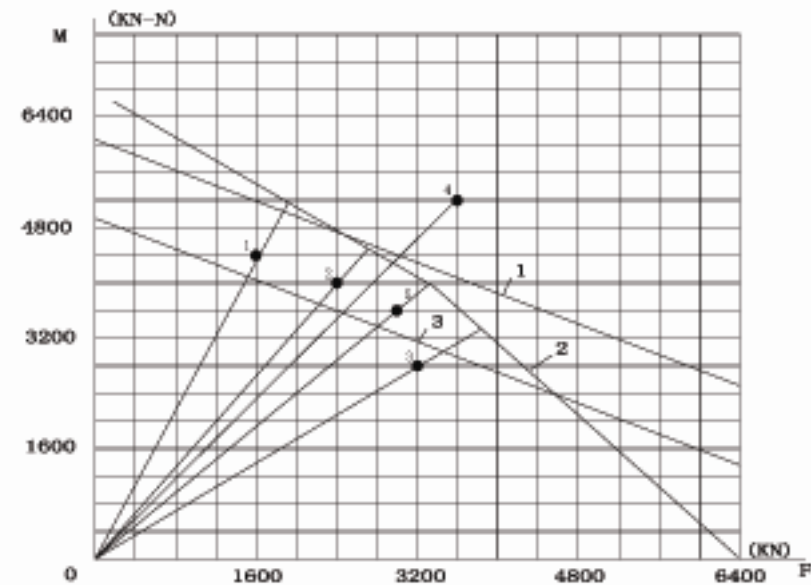

Figure 3 LY-Q005 Slewing Bearing Load Curve

Calculation Method 1:

Formula: $L_f = 1/(n_1/L_1 + n_2/L_2 + n_3/L_3 + \dots + n_n/L_n)$

Bearing life calculation working condition

Working hours 10%

$$fl_1 = Fac_1 / Fa'_1 = 1900 / 1600 = 1.1875$$

$$fl_1 = Mc_1 / M'_1 = 5200 / 4400 = 1.1818 \text{ Choose minimum value}$$

$$L_1 = (1.1818)^3 * 30000 \approx 49500 \text{ (revolution)}$$

Working hours 25%

$$fl_2 = Fac_2 / Fa'_2 = 2750 / 2400 = 1.146$$

$$fl_2 = Mc_2 / M'_2 = 4580 / 4000 = 1.145 \text{ Choose minimum value}$$

$$L_2 = (1.145)^3 * 30000 \approx 45000 \text{ (revolution)}$$

Working hours 60%

$$fl_3 = Fac_3 / Fa'_3 = 3900 / 3200 = 1.219$$

$$fl_3 = Mc_3 / M'_3 = 3420 / 2800 = 1.221 \text{ Choose minimum value}$$

$$L_3 = (1.219)^3 * 30000 \approx 54000 \text{ (revolution)}$$

Working hours 5%

$$fl_4 = Fac_4 / Fa'_4 = 3050 / 3600 = 0.847$$

$$fl_4 = Mc_4 / M'_4 = 4350 / 5200 = 0.836 \text{ Choose minimum value}$$

$$L_4 = (0.836)^3 * 30000 \approx 17500 \text{ (revolution)}$$

Estimated service life

$$L_f = 1 / (0.10 / 49500 + 0.25 / 45000 + 0.60 / 54000 + 0.05 / 17500) \approx 46400 \text{ (revolution)}$$

Calculation method 2

According to formula:

$$Fa' = (n_1 \cdot Fa^e + n_2 \cdot Fa^e + n_3 \cdot Fa^e + \dots + n_n \cdot Fa^e)^{1/e}$$

$$M' = (n_1 \cdot M^e + n_2 \cdot M^e + n_3 \cdot M^e + \dots + n_n \cdot M^e)^{1/e}$$

Therefore:

$$Fa' = (0.1 \cdot 1600^3 + 0.25 \cdot 2400^3 + 0.6 \cdot 3200^3 + 0.05 \cdot 3600^3)^{1/3}$$

$$= 2956.9 \text{ KN}$$

$$M' = (0.1 \cdot 4400^3 + 0.25 \cdot 4000^3 + 0.6 \cdot 2800^3 + 0.05 \cdot 5200^3)^{1/3}$$

$$= 3459.2 \text{ KN-m}$$

The gain load at point 5 in Figure3 from the above calculation result shows, the cross point load linking the original point on the carrying curve is:

$$Fac = 3400 \text{ KN};$$

$$Mc = 4080 \text{ KN-m}$$

$$fl = Fac / Fa' = 3400 / 2956.9 = 1.149$$

$$fl = Mc / M' = 4080 / 3459.2 = 1.149$$

Estimated service life:

$$L_f = (1.149)^3 * 30000 \approx 45500 \text{ (revolution)},$$

These two calculation methods are very similar.



LYC SR APPLICATION DYNAMICS QUESTIONNAIRE

Company Name :

Company Contact Name & Position :

Address :

Country :

Reference Name or Project No. :

Project : Existing New

Description of Application & End User :

Estimated Annual Consumption (EAC) :

Telephone No. :

Fax No. :

Email :

Physical Boundary Limitation : OD mm ID mm D mm

Orientation : Vertical Horizontal Interchange

Predominant Loading : Axial % Radial %

Moment Loads : Yes No

Gear Drive : Internal External None

RPM : No. RPM or Intermittent

Annual Service Time : No. of Hrs.

Describe Environmental Operating Conditions (Temperature, etc) :

Maximum Test Load : %

Special Sealing Requirements : Yes No

Special Torque Resistant Values (if required) : Nm

Special Grease Requirements : Yes No

Type :

Existing Drawing Supplied : Yes No

Customer Calculations Supplied : Yes No

Bearing Type Reference.....

Specify the following :

	Max.	Min.	Unit	% of Service Time
Axial Load :			kN	
Radial Load :			kN	
Tangential Forces :			kN	
Maximum Test Load :			kN	
Moment Load :			kNm	

Please detail any other special requirement :

.....

.....

.....

.....

.....

HEADQUARTER:



LUOYANG BEARING CORP. (GROUP)
ADDRESS: 96, Jianshe Road, Jianxi District,
Luoyang, Henan, China 471039
FAX: 0086 379 64912225

GENERAL MANAGER

Tel: 0086 379 64912292
Email: gm@lycbearing.com

AMERICA AND OCEANIA TRADE DEPT.

Tel: 0086 379 64985085
0086 379 64987094
Email: nam@lycbearing.com
sam@lycbearing.com

EUROPE TRADE DEPT.

Tel: 0086 379 64986627
Email: eur@lycbearing.com

ASIA AND AFRICA TRADE DEPT.

Tel: 0086 379 64985647
0086 379 64985949
Email: asi@lycbearing.com

OVERSEAS COMPANY:

LYC NORTH AMERICA, INC.

Address: 2600 Keslinger Road, Suite #H
Geneva, IL 60134, USA
Tel: 001 630 262 0601
Fax: 001 630 262-0638
Email: sales@Lycbearings.Com



LYC DO BRAZIL IMP. & EXP. LTDA.

Address: Rua Dr. Assis De Moura 44, Vila ariana,
Cep. 04120-150 Sao Paulo-Sp-Brasil
Tel : 0055 11 55396642
Fax : 0055 11 55722141
E-mail: lee@lyc.com.br



NOTE: LYC have taken every care to publish the specifications and recommendations within this catalogue, however, LYC cannot accept any responsibility for omissions or errors that may have occurred in this publication. LYC reserve the right to change without notice the content of this catalogue, consequently you should always check with the LYC SR Technical Department so as to ensure that the information you hold is current and correct.

FOUR-POINT CONTACT BALL SLEWING BEARING (UNGEARED)



轴承型号 Designation s	外形尺寸 Boundary dimensions			安装孔尺寸 Bolt hole diameter				结构尺寸 Structure dimensions						额定负荷 Basic load ratings Coa 10 ⁴ N	质量 Mass kg		
	D	d	H	D1	D2	n1	n2	φ 1	φ 2	D3	d1	H1	h			n3	φ 3
	mm			mm				mm		mm							
116752	480	260	60	444	296	16	16	14	14	360	380	60	—	—	—	75.4	55
116752K	480	260	60	—	—	—	—	—	—	360	380	60	—	—	—	75.4	58.6
176792	590	460	45	570	488	8	12	M10	10	518	542	45	—	—	—	62.6	35.9
176792K	590	460	45	570	488	12	12	10	10	518	542	45	—	—	—	62.6	36
176792K2M	590	460	45	570	488	12	8	10	10	526	534	45	—	—	—	94.4	30.8
1167/530	780	530	60	740	560	20	20	17	13	645	665	35	—	—	—	112	103
1167/560	720	560	36	690	590	12	12	14	12	638.5	641.5	33	3	—	—	70.8	40.3
1167/560K	720	560	36	690	590	12	32	M12	16	634	646	36	3	—	—	70.8	39.2
1167/560M	720	560	36	690	590	12	12	14	12	638.5	641.5	36	3	—	—	70.8	38.1
1168/560	780	560	60	—	—	—	—	—	—	645	668	60	3	—	—	224	103
11768/630	780	630	69	—	—	—	—	—	—	718	722	69	—	—	—	111	79.4
1167/700	900	700	36	860	740	12	12	M16	17	796	804	36	3	—	—	179	60
E787/760G2	950	760	80	915	795	24	24	18	M16	853.5	856.5	71	9	4	M10×1	203	138
3-640	1000	775	64	948	802	24	12/12	M12	13/M12	878	882	49	15	2	M8×1	196	112
3-640K	1000	775	64	948	802	24	12/12	M12	13/M12	878	882	49	15	2	M8	196	112
787/800G	1050	800	90	1012	838	30	30	20	20	923	927	76	16	3	M10×1	215	192
71769/850Y	1120	850	85	1074	924	12	12	M20	22	995	1010	85	—	—	—	151	248
71769/850G2K	1120	850	85	1074	924	12	12	17	22	999	1003	85	—	—	—	210	257
787/932G2	1200	932	120	1148	984	40	40	26	M24	1064	1068	100	20	4	G1/4in	349	328

FOUR-POINT CONTACT BALL SLEWING BEARING (UNGEARED)

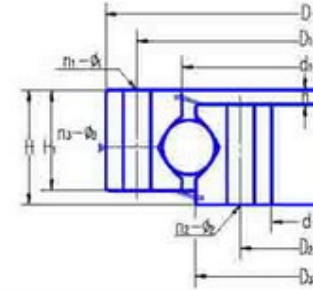
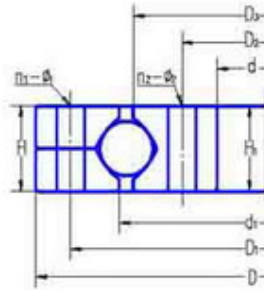

轴承型号 Designation ns	外形尺寸 Boundary dimensions			安装孔尺寸 Bolt hole diameter						结构尺寸 Structure dimensions					额定负荷 Basic load ratings Coa 10 ⁴ N	质量 Mass kg	
	D	d	H	D1	D2	n1	n2	φ 1	φ 2	D3	d1	H1	h	n3			φ 3
	mm			mm				mm		mm							
787/960G2	1165	960	90	1135	1040	36	36	18	M16	1073	1077	78	14	6	M10×1	249	202
787/1000G2	1250	1000	100	1206	1044	12	12	18	M16	1123	1127	90	10	3	M10×1	540	283
787/1260G2	1509	1260	90	1465	1315	36	36	22	M20	1386	1389	70	14	2	ZG1/8in	378	274
71169/1400Y	1820	1400	136	1750	1470	24	24	35	35	1608	1612	136	—	4	M10×1	611	1114
71169/1400Y1	1820	1400	136	1750	1470	24	24	35	35	1608	1612	136	—	4	M10×1	1070	1120
787/1440G2	1780	1440	100	1730	1494	48	48	22	M20	1618	1622	85	15	4	M12×1.25	503	533
787/1628G2	1927	1628	130	1875	1680	36	36	26	M24	1774	1778	115	15	6	G1/4in	692	732
787/1700KM	2000	1700	150	1950	1750	24	24	21	21	1842	1858	130	20	4	M10×1	684	826
KDL 900-6	1050	832	56	1020	862	12	12	18	18	942	946	45	—	4	M6	227	52.5
LY-Q007	485	275	55	453	307	16	16	18	M16	381	386	50	5	4	M10×1	87.2	43.7
LY-Q007K	485	275	55	453	307	16	16	18	18	381	386	50	5	4	M10×1	87.2	43.7
LY-Q020	440	240	55	400	280	18	18	M20-7H	22	340	342	50	5	3	M10×1	78.2	34.7

FOUR-POINT CONTACT BALL SLEWING BEARING (WITH EXTERNAL GEAR)

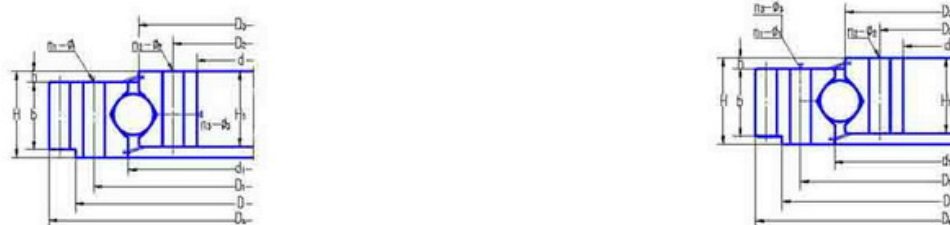

轴承型号 Designations	外形尺寸 Boundary dimensions			安装孔尺寸 Bolt hole diameter				结构尺寸 Structure dimensions						齿轮参数 Gear parameters				额定负荷 Basic load ratings Coa 10 ⁴ N	质量 Mass kg			
	D	d	H	D1	D2	n1	n2	φ 1	φ 2	D3	d1	H1	h	n3	φ 3	m	Da			Z	b	x
	mm			mm				mm		mm							mm		mm			
D178794	694	470	77	630	500	18	18	M16	18	567.5	564.5	64	13	6	M10×1	6	696	114	60	0	157	93.1
1787/600G	786	600	72	740	636	20	24	M18×2.5	19	689	691	60	7	4	ZG1/8in	6	789	131	50	0	107	94.1
1787/674G2	853	674	70	825	709	3.4	23	20	M20	764	768	59	10	2	ZG1/8in	7	889	125	50	0	183	89
1787/674G2K	853	674	70	825	709	3.4	24	18	18	764	768	59	10	2	ZG1/8in	7	889	125	50	0	183	88.6
1787/710G2	894	710	67	845	744	8	8	M10	M10	798	806	58	9	3	M10×1	6	924	152	55	0	179	107
1787/710G2K	894	710	67	875	760	8	12	M10	M12	798	806	58	9	3	M10×1	6	924	152	55	0	179	107
1787/710G2K1	894	710	67	865	744	20	20	13	13	798	806	58	9	4	M10×1	6	924	152	55	0	179	107
1787/800G	1050	800	90	1012	838	30	30	20	20	923	927	76	16	3	M10×1	6	1092	180	60	0	215	217
1787/800GK	1050	800	90	1012	838	30	30	20	20	923	927	76	16	3	M10×1	6	1092	180	60	0	215	217
1788/1040G2	—	1040	80	1220	1080	30	30	M16	17.5	1153	1157	70	10	—	—	10	1314.1	125	70	0	297	251
1787/1060G	1335	1060	109	1295	1105	24	24	M20	22	1198	1202	100	9	4	M8×1	10	1388	138	80	-0.6	501	407
1787/1075	1365	1075	120	1310	1130	36	36	26	26	1218	1222	105	15	4	M8×1	8	1424	176	90	0	463	463
1787/1075K	1365	1075	130	1310	1130	36	36	24	24	1218	1222	105	10	—	—	10	1420	140	120	0	463	550
1787/1075G2	1365	1075	120	1310	1130	36	36	24	24	1218	1222	105	15	4	M10×1	10	1424.9	138	90	+1.4	463	463
1787/1075G2K	1365	1075	120	1310	1130	36	36	M24	26	1218	1222	105	15	4	M8×1	8	1424	176	90	0	463	463
1787/1330G2	1475	1330	82.4	1510	1362	24	24	18.5	18.5	1439	1445	70	12.4	6	M10×1	9	1584	174	70	0	353	280
3-647G	1407	1352	100	1370	1404	18	13	M8	M10	1390	1394	63	—	8	6	4.5	1449	320	60	0	216	143
1788/1410G2	—	1410	85	1590	1454	36	36	M16	17.5	1525	1529	70	15	—	—	10	1676.4	160	70	0	395	312
1787/1640G	2050	1640	160	1990	1710	30	30	28	28	1844	1856	140	20	2	M14×1.5	10	2108	210	105	-0.6	1118	1264
1787/1700	1945	1700	120	1900	1750	24	24	M18	21	1825	1845	110	10	4	M10×1	5	1970	392	35	0	405	516
1789/1700GM	2052	1700	100	1980	1780	24	24	20	M18	1878	1882	90	10	4	M14×1.5	5	2080	414	50	0	551	678
1787/2650G2	2885	2650	100	2850	2700	48	48	M20	M20	2777	2781	80	10	6	ZG1/4in	12	2949.6	244	80	0	913	751

FOUR-POINT CONTACT BALL SLEWING BEARING (WITH INTERNAL GEAR)

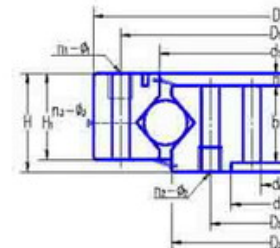
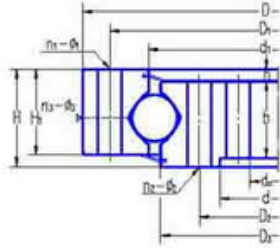

轴承型号 Designations	外形尺寸 Boundary dimensions			安装孔尺寸 Bolt hole diameter					结构尺寸 Structure dimensions						齿轮参数 Gear parameters					额定负荷 Basic load ratings Coa 10 ⁴ N	质量 Mass kg	
	D	d	H	D1	D2	n1	n2	φ1	φ2	D3	d1	H1	h	n3	φ3	m	da	Z	b			x
2788/850K	976	850	80	—	—	—	—	—	—	916	919	80	—	—	2	916	456	20	0	174	117	
3-646G2	1200	—	56	1170	1044	16	24	17.5	10.5	1088	1092	46	12	4	M8×1	6	985	166	44	0	210	84.1
2782/1000GK	1270	1000	100	1220	1050	24/2×2	24/2×2	17/M12	17/M12	1133	1137	85	15	2	M10×1	6	972.6	164	70	0	384	322
2787/1210G2	1530	1210	122	1480	1260	40	40	26	26	1368	1372	108	12	4	M10×1	10	1164	118	80	0	713	540
2787/1400GK	1715	1400	110	1660	1460	24	24	M20	M20	1558	1562	95	15	2	M12×1.25	6	1364.5	230	77	-0.35	365	545
2787/1400GK1	1715	1400	110	1660	1460	24	24	23	23	1558	1562	95	15	2	M10×1	6	1364.5	230	77	-0.35	365	545
2787/1440	1780	1440	100	1730	1494	48	48	22	M20	1618	1622	85	10	4	M12×1.25	8	1400	177	50	0	503	554
2787/1440G	1780	1440	100	1730	1494	48	48	22	M20	1618	1622	85	10	4	M12×1.25	8	1400	177	50	0	578	554
2768/1440G	1780	1440	104	1730	1494	48	48	22	M20	1613	1627	87	10	6	M12×1.25	8	1400	177	52	0	578	555
2787/1525G2	1875	1525	140	1815	1585	42	42	29	29	1698	1702	122	17	4	M12×1.25	16	1452.33	92	110	+0.35	873	1019
2788/1712	2050	1790	112	2006	1847	36	72	22	22	1925	1926	92	12	18	M10×1	16	1712	108	100	-0.5	604	663
2789/2230	2488	2230	160	2445	2275	48	48	M20	M22	2337.5	2342.5	135	5	8	ZG1/4in	18	2144.25	121	145	0	1247	1114
2789/2240G2	2500	2240	140	2454	2280	56	56	M24	M24	2357.5	2362.5	115	5	8	M14×1.5	18	2145.6	121	125	0	856	1161
2789/2735	2990	2735	160	2954	2770	48	48	M20	M24	2835	2845	135	5	8	ZG1/4in	22	2624.62	121	144	0	1559	1457

FOUR-POINT CONTACT BALL SLEWING BEARING

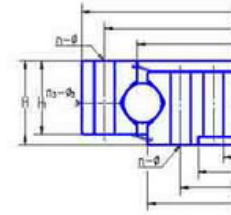
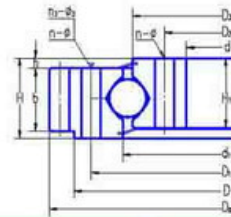
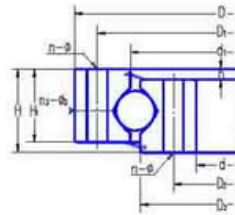

轴承型号Designations			外形尺寸 Boundary dimensions			安装孔尺寸 Bolt hole diameter				结构尺寸 Structure dimensions					齿轮参数 Gear parameters					额定负荷 Basic load ratings	质量 Mass			
无齿式 non-gear type	外齿式 external gear type	内齿式 internal gear type	D	d	H	D1	D2	n	φ	D3	d1	H1	h	n3	φ3	m	Da	Z	da	Z	b	x	Coa	kg
			mm			mm				mm										10 ⁴ N				
010-30-500-12	011-30-500** 012-30-500**	013-30-500** 014-30-500**	602	398	80	566	434	20	18	498.5	501.5	70	10	4	M10×1	5	630	123	365	74	60	+0.5	129	75.8
010-30-560**	011-30-560** 012-30-560**	013-30-560** 014-30-560-12	602	458	80	626	494	20	18	558.5	561.5	70	10	4	M10×1	5	690	135	425	86	60	+0.5	144	94
010-30-630**	011-30-630** 012-30-630**	013-30-630** 014-30-630**	662	458	80	626	494	20	18	558.5	561.5	70	10	4	M10×1	6	690	112	426.5	72	60	+0.5	144	94
010-30-710**	011-30-710** 012-30-710**	013-30-710** 014-30-710**	732	528	80	696	564	24	18	628.5	631.5	70	10	4	M10×1	6	774	126	492	83	60	+0.5	187	110
010-30-710**	011-30-710** 012-30-710**	013-30-710** 014-30-710**	732	528	80	696	564	24	18	628.5	631.5	70	10	4	M10×1	8	776	94	488	62	60	+0.5	187	110
010-30-955-11	011-30-955** 012-30-955**	013-30-955** 014-30-955**	812	608	80	776	644	24	18	708.5	711.5	70	10	4	M10×1	6	852	139	570	86	60	+0.5	212	120
010-30-955-11	011-30-955** 012-30-955**	013-30-955** 014-30-955**	812	608	80	776	644	24	18	708.5	711.5	70	10	4	M10×1	8	856	104	568	72	60	+0.5	212	120
010-40-800**	011-40-800** 012-40-800**	013-40-800-12 014-40-800**	1098	893	90	1060	845	48/47	22	956.5	953.5	71	19	6	M10×1	8	968	118	632	80	80	+0.5	270	126
010-40-800**	011-40-800** 012-40-800**	013-40-800-12 014-40-800**	922	678	100	878	722	30	22	798.5	801.5	90	10	6	M10×1	8	968	118	632	80	80	+0.5	313	256
010-40-900**	011-40-900** 012-40-900**	013-40-900** 014-40-900**	922	678	100	878	722	30	22	798.5	801.5	90	10	6	M10×1	10	970	94	630	64	80	+0.5	313	256
010-40-900**	011-40-900** 012-40-900**	013-40-900** 014-40-900**	1022	778	100	978	822	30	22	898.5	901.5	90	10	6	M10×1	8	1064	130	736	93	80	+0.5	355	240
010-40-900**	011-40-900** 012-40-900**	013-40-900** 014-40-900**	1022	778	100	978	822	30	22	898.5	901.5	90	10	6	M10×1	10	1070	104	730	74	80	+0.5	355	240
010-40-1000**	011-40-1000-12 012-40-1000**	013-40-1000** 014-40-1000**	1122	878	100	1078	922	36	22	998.5	1001.5	90	10	6	M10×1	10	1190	116	820	83	80	+0.5	394	305
010-40-1000**	011-40-1000-12 012-40-1000**	013-40-1000** 014-40-1000**	1122	878	100	1078	922	36	22	998.5	1001.5	90	10	6	M10×1	12	1188	96	816	69	80	+0.5	394	305
010-40-1120**	011-40-1120** 012-40-1120**	013-40-1120** 014-40-1120**	1242	998	100	1198	1042	36	22	1118	1122	90	10	6	M10×1	10	1300	127	940	95	80	+0.5	443	300
010-40-1120**	011-40-1120** 012-40-1120**	013-40-1120** 014-40-1120**	1242	998	100	1198	1042	36	22	1118	1122	90	10	6	M10×1	12	1308	106	936	79	80	+0.5	443	300
010-40-1120**	011-40-1120-12K 012-40-1120-12K1	-- --	1242	998	100	1198	1042	18	22/M20	1118.5	1121.5	90	10	6	M10×1	10	1300	127	--	--	80	+0.5	334	352
010-40-1120**	011-40-1120-12K 012-40-1120-12K1	-- --	1242	998	100	1198	1042	36	22	1118	1121	90	10	6	M10×1	10	1298	127	--	--	80	+0.5	334	334
010-45-1250**	011-45-1250** 012-45-1250**	013-45-1250** 014-45-1250**	1390	1110	110	1337	1163	40	26	1248	1252	100	10	6	M10×1	12	1452	118	1044	88	90	+0.5	554	420
010-45-1250**	011-45-1250** 012-45-1250**	013-45-1250** 014-45-1250**	1390	1110	110	1337	1163	40	26	1248	1252	100	10	6	M10×1	14	1456	101	1036	75	90	+0.5	554	420
010-45-1400**	011-45-1400** 012-45-1400**	013-45-1400** 014-45-1400**	1540	1260	110	1487	1313	40	26	1398	1402	100	10	6	M10×1	12	1608	131	1188	100	90	+0.5	617	480
010-45-1400**	011-45-1400** 012-45-1400**	013-45-1400** 014-45-1400**	1540	1260	110	1487	1313	40	26	1398	1402	100	10	6	M10×1	14	1610	112	1190	86	90	+0.5	617	480
010-45-1600**	011-45-1600** 012-45-1600**	013-45-1600** 014-45-1600**	1740	1460	110	1687	1513	45	26	1598	1602	100	10	8	M10×1	14	1820	127	1386	100	90	+0.5	702	550
010-45-1600**	011-45-1600** 012-45-1600**	013-45-1600** 014-45-1600**	1740	1460	110	1687	1513	45	26	1598	1602	100	10	8	M10×1	16	1824	111	1376	87	90	+0.5	702	550
010-45-1800**	011-45-1800** 012-45-1800**	013-45-1800** 014-45-1800**	1940	1660	110	1887	1713	45	26	1798	1802	100	10	8	M10×1	14	2016	141	1568	113	90	+0.5	793	610
010-45-1800**	011-45-1800** 012-45-1800**	013-45-1800** 014-45-1800**	1940	1660	110	1887	1713	45	26	1798	1802	100	10	8	M10×1	16	2016	123	1568	99	90	+0.5	793	610
010-45-1800**	011-45-1800-05 012-45-1800**	013-45-1800** 014-45-1800**	--	1660	110	1887	1713	45	26	1798	1802	100	10	5	M10×1	14	2016	141	--	--	100	+0.5	594	684
010-60-2000**	011-60-2000** 012-60-2000-12K	013-60-2000** 014-60-2000**	2178	1825	144	2110	1891	48	33	1998	2002	132	12	8	M10×1	16	2272	139	1728	109	120	+0.5	1210	1100
010-60-2000**	011-60-2000** 012-60-2000-12K	013-60-2000** 014-60-2000**	2178	1825	144	2110	1891	48	33	1998	2002	132	12	8	M10×1	16	2240	139	--	--	120	+0.5	1122	970
010-60-2000**	011-60-2000** 012-60-2000**	013-60-2000** 014-60-2000**	2178	1825	144	2110	1891	48	33	1998	2002	132	12	8	M10×1	18	2268	123	1728	97	120	+0.5	1210	1100

FOUR-POINT CONTACT BALL SLEWING BEARING

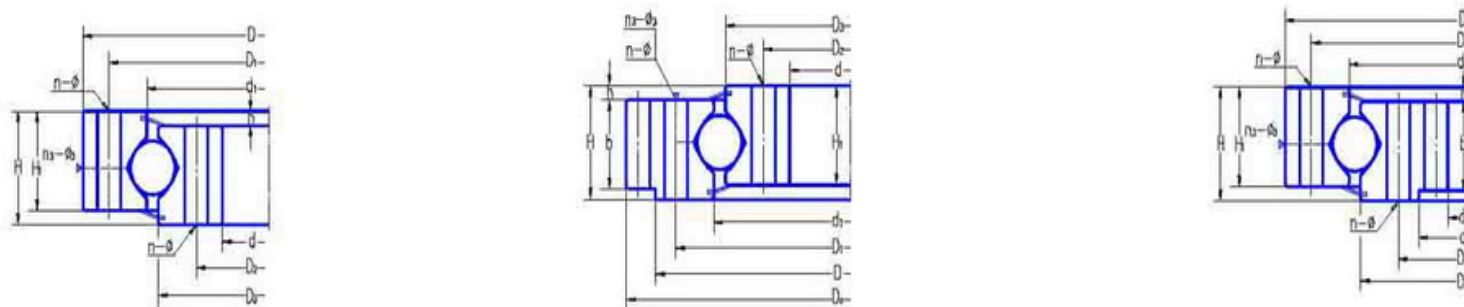

轴承型号Designations			外形尺寸 Boundary dimensions		安装孔尺寸 Bolt hole diameter				结构尺寸 Structure dimensions					齿轮参数 Gear parameters					额定负荷 Basic load ratings	质量 Mass				
无齿式 non-gear type	外齿式 external gear type	内齿式 internal gear type	D	d	H	D1	D2	n	φ	D3	d1	H1	h	n3	φ3	m	Da	Z	da	Z	b	x	Coa 10 ⁴ N	kg
010-60-2240**	011-60-2240**	013-60-2240**	2418	2065	144	2350	2131	48	33	2237.5	2242.5	132	12	8	M10×1	16	2496	153	1984	125	120	+0.5	1350	1250
	012-60-2240**		2418	2065	144	2350	2131	48	33	2237.5	2242.5	132	12	8	M10×1	18	2502	136	1980	111	120	+0.5	1350	1250
010-60-2500**	011-60-2500**	013-60-2500**	2678	2325	144	2610	2391	56	33	2497.5	2502.5	132	12	8	M10×1	18	2772	151	2232	125	120	+0.5	1500	1400
	012-60-2500**		2678	2325	144	2610	2391	56	33	2497.5	2502.5	132	12	8	M10×1	20	2780	136	2220	112	120	+0.5	1500	1400
010-60-2800**	011-40-2500-12	013-60-2800**	2678	2325	144	2610	2391	56	33	2498	2502	132	12	8	M10×1	18	2769.7	151	—	—	120	+0.5	820	890
	011-60-2800**		2978	2625	144	2910	2691	56	33	2797.5	2802.5	132	12	8	M10×1	18	3078	168	2520	141	120	+0.5	1680	1600
	012-60-2800**		2978	2625	144	2910	2691	56	33	2797.5	2802.5	132	12	8	M10×1	20	3080	151	2520	127	120	+0.5	1680	1600
010-75-3150**	011-75-3150**	013-75-3150**	3376	2922	174	3286	3014	56	45	3147.5	3152.5	162	12	8	M10×1	20	3480	171	2820	142	150	+0.5	2380	2800
	012-75-3150**		3376	2922	174	3286	3014	56	45	3147.5	3152.5	162	12	8	M10×1	22	3476	115	2816	129	150	+0.5	2380	2800
010-75-3550**	011-75-3550**	013-75-3550**	3776	3322	174	3686	3414	56	45	3547.5	3552.5	162	12	8	M10×1	20	3880	191	3220	162	150	+0.5	2690	3200
	012-75-3550**		3776	3322	174	3686	3414	56	45	3547.5	3552.5	162	12	8	M10×1	22	3894	174	3212	147	150	+0.5	2690	3200
010-75-4000**	011-75-4000**	013-75-4000**	4226	3772	174	4136	3864	60	45	3997.5	4002.5	162	12	10	M10×1	22	4334	194	3652	167	150	+0.5	3020	3600
	012-75-4000**		4226	3772	174	4136	3864	60	45	3997.5	4002.5	162	12	10	M10×1	25	4350	171	3650	147	150	+0.5	3020	3600
010-75-4500**	011-75-4500**	013-75-4500**	4726	4272	174	4636	4364	60	45	4497.5	4502.5	162	12	10	M10×1	22	4840	271	4158	190	150	+0.5	3410	4000
	012-75-4500**		4726	4272	174	4636	4364	60	45	4497.5	4502.5	162	12	10	M10×1	25	4850	191	4150	167	150	+0.5	3410	4000

DOUBLE-ROW ANGULAR CONTACT THRUST BALL SLEWING BEARINGS

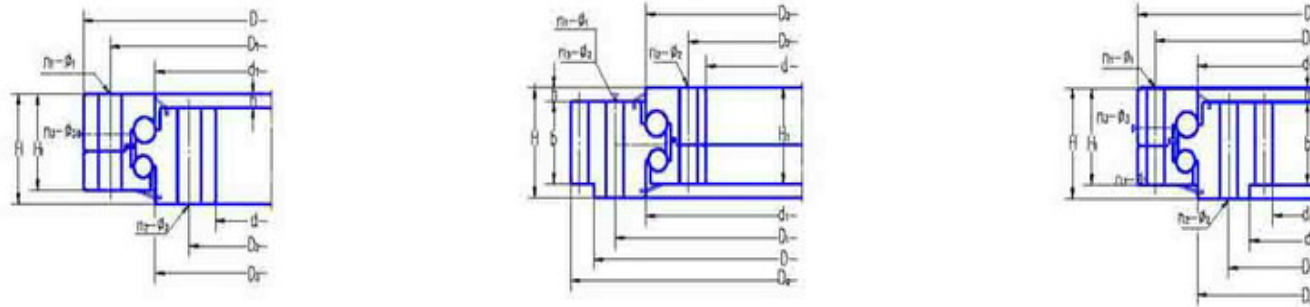

轴承型号 Designations	外形尺寸 Boundary dimensions			安装孔尺寸 Bolt hole diameter						结构尺寸 Structure dimensions						齿轮参数 Gear parameters					额定负荷 Basic load ratings Coa 10 ⁴ N	质量 Mass kg
	D	d	H	D1	D2	n1	n2	φ1	φ2	D3	d1	H1	h	n3	φ3	m	da	Z	b	x		
	mm			mm				mm		mm							mm		mm			
	no gear																					
5787/1916G2	2320	1916	150	2245	1980	42	42	34	34	2146	2150	135	20	12	M12	--	--	--	--	--	1096	1251
	external gear																					
6787/820G	1150	820	125	1100	880	14/4	8	25/22	32	1020	1040	130	5	2×2	M10×1	12	1206	99	75	-0.25	297	508
6787/1600G	2000	1600	175	1920	1675	10	20	38	38	1840	1865	190	15	4×2	M10×1	14	2066.4	146	120	-0.2	705	1531
6788/1600G	2000	1600	175	1920	1675	24	24	32	32	1840	1865	190	15	4×2	M10×1	6	2154.6	358	140	-0.45	705	1576
6789/3405G	3638	3405	185	3700	3465	48	48	35	35	3638	3630	185	45	12	M12×1.25	18	3852	212	120	0	1860	2632
	internal gear																					
7787/1310G	1600	1310	135	1550	1365	32	32	26	26	1414	1436	140	5	4	M10×1	16	1214.4	77	100	+0.25	433	691
7787/2728K	3100	2728	210	3040	2780	36	36	25	26	2874	2880	200	42	4	M14×1.5	10	2652	266	105	+0.6	814	2537

DOUBLE-ROW ANGULAR CONTACT THRUST BALL SLEWING BEARINGS

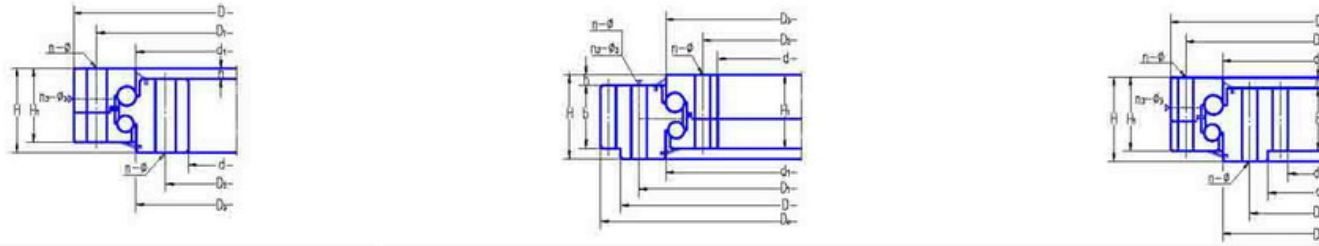

轴承型号 Designations			外形尺寸 Boundary dimensions		安装孔尺寸 Bolt hole diameter				结构尺寸 Structure dimensions						齿轮参数 Gear parameters						额定负荷 Basic load ratings	质量 Mass		
无齿式 non-gear type	外齿式 external gear type	内齿式 internal gear type	D	d	H	D1	D2	n	φ	D3 (D3')	d1 (d1')	H1	h	n3	φ3	m	Da	Z	da	Z	b	x	Coa 10 ⁴ N	kg
020-25-500**	021-25-500**	023-25-500**	616	384	106	580	420	20	18	523	517	96	26	4	M10×1	5	645	126	355	72	60	+0.5	121	100
	022-25-500**	024-25-500**	616	384	106	580	420	20	18	(483)	(477)	96	26	4	M10×1	6	648	105	348	59	60	+0.5	121	100
020-25-560**	021-25-560**	023-25-560**	676	444	106	640	480	20	18	583	577	96	26	4	M10×1	5	705	138	415	84	60	+0.5	134	115
	022-25-560**	024-25-560**	676	444	106	640	480	20	18	(543)	(537)	96	26	4	M10×1	6	708	115	408	69	60	+0.5	134	115
020-25-630**	021-25-630**	023-25-630**	746	514	106	710	550	24	18	653	647	96	26	4	M10×1	6	792	129	480	81	60	+0.5	153	130
	022-25-630**	024-25-630**	746	514	106	710	550	24	18	(613)	(607)	96	26	4	M10×1	8	792	96	472	60	60	+0.5	153	130
020-25-710**	021-25-710**	023-25-710**	826	594	106	790	630	24	18	733	727	96	26	4	M10×1	6	864	141	558	94	60	+0.5	173	140
	022-25-710**	024-25-710**	826	594	106	790	630	24	18	(693)	(687)	96	26	4	M10×1	8	864	105	552	70	60	+0.5	173	140
020-30-800**	021-30-800**	023-30-800**	942	658	124	898	702	30	22	828	822	114	29	6	M10×1	8	984	120	616	78	80	+0.5	230	200
	022-30-800**	024-30-800**	942	658	124	898	702	30	22	(778)	(771)	114	29	6	M10×1	10	990	96	610	62	80	+0.5	230	200
020-30-900**	021-30-900**	023-30-900**	1042	758	124	998	802	30	22	928	922	114	29	6	M10×1	8	1088	133	712	90	80	+0.5	258	250
	022-30-900**	024-30-900**	1042	758	124	998	802	30	22	(878)	(871)	114	29	6	M10×1	10	1090	106	710	72	80	+0.5	258	250
020-30-1000**	021-30-1000**	023-30-1000**	1142	858	124	1098	902	36	22	1028	1022	114	29	6	M10×1	10	1200	117	810	82	80	+0.5	286	300
	022-30-1000**	024-30-1000**	1142	858	124	1098	902	36	22	(978)	(971)	114	29	6	M10×1	12	1200	97	792	67	80	+0.5	286	300
020-30-1120**	021-30-1120**	023-30-1120**	1262	978	124	1218	1022	36	22	1148	1142	114	29	6	M10×1	10	1320	129	920	93	80	+0.5	321	340
	022-30-1120**	024-30-1120**	1262	978	124	1218	1022	36	22	(1098)	(1091)	114	29	6	M10×1	12	1320	107	912	77	80	+0.5	321	340
020-40-1250**	021-40-1250**	023-40-1250**	1426	1074	160	1374	1126	40	26	1286	1282	150	39	6	M10×1	12	1500	122	1008	85	90	+0.5	482	580
	022-40-1250**	024-40-1250**	1426	1074	160	1374	1126	40	26	(1218)	(1214)	150	39	6	M10×1	14	1498	104	1008	73	90	+0.5	482	580
020-40-1400**	021-40-1400**	023-40-1400**	1576	1224	160	1524	1272	40	26	1436	1432	150	39	6	M10×1	12	1644	134	1152	97	90	+0.5	543	650
	022-40-1400**	024-40-1400**	1576	1224	160	1524	1272	40	26	(1368)	(1364)	150	39	6	M10×1	14	1652	115	1148	83	90	+0.5	543	650
020-40-1600**	021-40-1600**	023-40-1600**	1776	1424	160	1724	1476	45	26	1636	1632	150	39	8	M10×1	14	1848	129	1344	97	90	+0.5	620	750
	022-40-1600**	024-40-1600**	1776	1424	160	1724	1476	45	26	(1568)	(1564)	150	39	8	M10×1	16	1856	113	1344	85	90	+0.5	620	750
020-40-1800**	021-40-1800**	023-40-1800**	1976	1624	160	1924	1676	45	26	1836	1832	150	39	8	M10×1	14	2058	144	1540	111	90	+0.5	692	820
	022-40-1800**	024-40-1800**	1976	1624	160	1924	1676	45	26	(1768)	(1764)	150	39	8	M10×1	16	2064	126	1536	97	90	+0.5	692	820
020-50-2000**	021-50-2000**	023-50-2000**	2215	1785	190	2149	1851	48	33	2038	2032	178	47	8	M10×1	16	2304	141	1696	107	120	+0.5	987	1150
	022-50-2000**	024-50-2000**	2215	1785	190	2149	1851	48	33	(1968)	(1962)	178	47	8	M10×1	18	2304	125	1692	95	120	+0.5	987	1150
020-50-2240**	021-50-2240**	023-50-2240**	2455	2025	190	2389	2091	48	33	2278	2272	178	47	8	M10×1	16	2544	156	1936	122	120	+0.5	1110	1500
	022-50-2240**	024-50-2240**	2455	2025	190	2389	2091	48	33	(2208)	(2202)	178	47	8	M10×1	18	2556	139	1926	108	120	+0.5	1110	1500

DOUBLE-ROW ANGULAR CONTACT THRUST BALL SLEWING BEARINGS

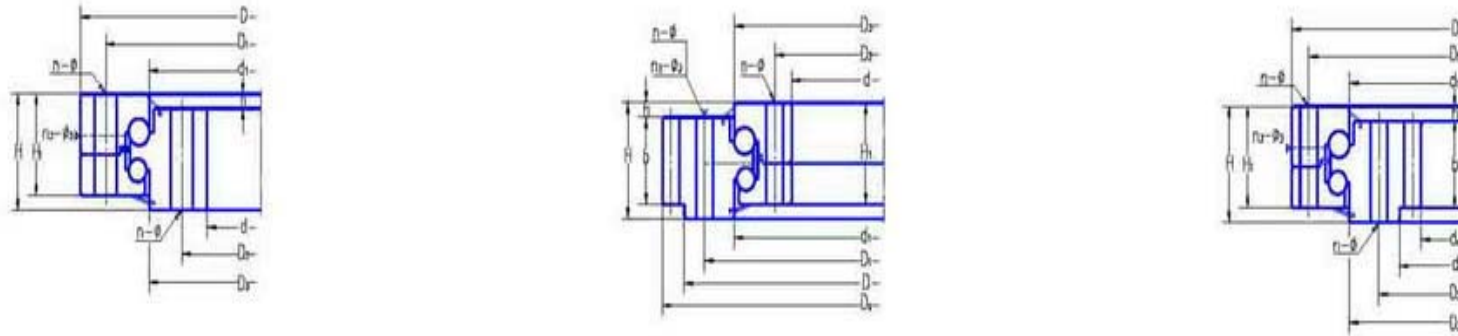

轴承型号Designations			外形尺寸 Boundary dimensions			安装孔尺寸 Bolt hole diameter				结构尺寸 Structure dimensions					齿轮参数 Gear parameters					额定负荷 Basic load ratings	质量 Mass			
无齿式 non-gear type	外齿式 external gear type	内齿式 internal gear type	D	d	H	D1	D2	n	φ	D3 (D3')	d1 (d1')	H1	h	n3	φ3	m	Da mm	Z	da mm	Z	b mm	x	Coa 10 ⁴ N	kg
020-50-2500**	021-50-2500**	023-50-2500**	2715	2285	190	2649	2351	56	33	2538	2532	78	47	8	M10×1	18	2804	153	2196	123	120	+0.5	1110	1500
	022-50-2500**	024-50-2500**	2715	2285	190	2649	2351	56	33	(2468)	(2462)	78	47	8	M10×1	20	2820	138	2180	110	120	+0.5	1110	1500
	021-50-2500-12		2715	2285	190	2649	2351	56	33	2550	2538	178	47	8	M10×1	18	2804.4	153			120	+0.5	1117	2031
020-50-2800**	021-50-2800**	023-50-2800**	3015	2585	190	2949	2651	56	33	2838	2832	178	47	8	M10×1	18	3114	170	2484	139	120	+0.5	1390	1900
	022-50-2800**	024-50-2800**	3015	2585	190	2949	2651	56	33	(2768)	(2762)	178	47	8	M10×1	20	3120	153	2480	125	120	+0.5	1390	1900
020-60-3150**	021-60-3150**	023-60-3150**	3428	2872	226	3338	2962	56	45	3198	3192	214	56	8	M10×1	20	3540	174	2760	139	150	+0.5	1870	3300
	022-60-3150**	024-60-3150**	3428	2872	226	3338	2962	56	45	(3108)	(3102)	214	56	8	M10×1	22	3542	158	2750	126	150	+0.5	1870	3300
020-60-3550**	021-60-3550**	023-60-3550**	3828	3272	226	3738	3362	56	45	3598	3592	214	56	8	M10×1	20	3940	194	3160	159	150	+0.5	2110	3700
	022-60-3550**	024-60-3550**	3828	3272	226	3738	3362	56	45	(3508)	(3502)	214	56	8	M10×1	22	3938	176	3168	145	150	+0.5	2110	3700
020-60-4000**	021-60-4000**	023-60-4000**	4278	3722	226	4188	3812	60	45	4048	4042	214	56	10	M10×1	22	4400	197	3608	165	150	+0.5	2370	4200
	022-60-4000**	024-60-4000**	4278	3722	226	4188	3812	60	45	(3958)	(3952)	214	56	10	M10×1	25	4400	173	3600	145	150	+0.5	2370	4200
020-60-4500**	021-60-4500**	023-60-4500**	4778	4222	226	4688	4312	60	45	4548	4542	214	56	10	M10×1	22	4884	219	4114	188	150	+0.5	2670	4700
	022-60-4500**	024-60-4500**	4778	4222	226	4688	4312	60	45	(4458)	(4452)	214	56	10	M10×1	25	4900	193	4100	165	150	+0.5	2670	4700

CROSS CYLINDRICAL ROLLER SLEWING BEARING (UNGEARED)

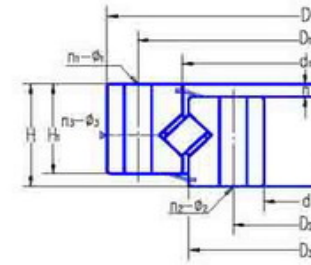
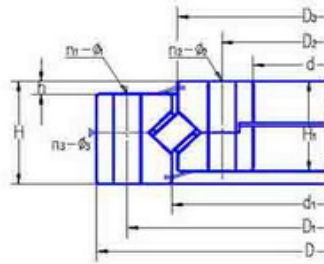

轴承型号 Designation s	外形尺寸 Boundary dimensions			安装孔尺寸 Bolt hole diameter						结构尺寸 Structure dimensions						额定负荷 Basic load ratings Coa 10 ³ N	质量 Mass kg
	D	d	H	D1	D2	n1	n2	φ 1	φ 2	D3	d1	H1	h	n3	φ 3		
	mm			mm				mm		mm							
79764	550	320	85	515	365	12	8	17	18	438	442	75	10	—	—	88.2	85.6
797/600G2	900	600	125	848	690	30	29	26	M24	750	754	105	15	3	M10×1	280	246
797/670	907	670	85	870	730	12	8	M16	18	808	812	75	10	—	—	165	170
797/700G	1000	700	140	940	770	24	24	M20	22	879	882	130	20	4	M10×1	254	370
797/845G2	1150	845	130	1100	895	24	24	22	22	1024	1030	105	10	6	M6	401	393
797/870G	1180	870	115	1125	920	18	18	28	28	1023	1027	100	15	2	M8×1	292	355
797/870K	1180	870	115	1125	920	18	18	28	28	1023	1027	100	15	2	M10×1	232	355
797/870G2K1	1180	870	115	1125	920	18	18	28	28	1023	1027	100	15	2	M10×1	320	356
797/962G2	1200	962	90	—	—	—	—	—	—	1088	1092	76	10	—	—	254	224
792/1000G2	1270	1000	100	1220	1050	36	36	19	19	1132	1138	85	15	4	M10×1	333	303
792/1000G2K	1270	1000	100	1220	1050	36	36	19	19	1132	1138	85	15	3	9	333	303
792/1000G2K1	1270	1000	100	1220	1050	36	36	19	19	1132	1138	85	15	—	—	333	303
792/1000G2K2	1270	1000	100	1220	1050	36	36	19	19	1132	1138	85	15	—	—	333	303
797/1060G2	1400	1060	120	—	—	—	—	—	—	1248	1252	120	—	—	—	429	596
797/1200G2	1520	1200	90	—	—	—	—	—	—	1356	1364	90	—	—	—	409	504
792/1250G2	1700	1250	155	1650	1330	24	24	26	26	1446	1450	140	10	6	M10×1	602	1103

CROSS CYLINDRICAL ROLLER SLEWING BEARING (UNGEARED)

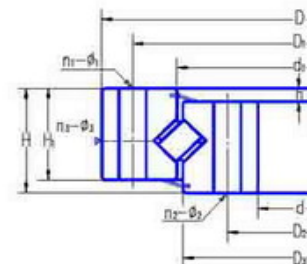
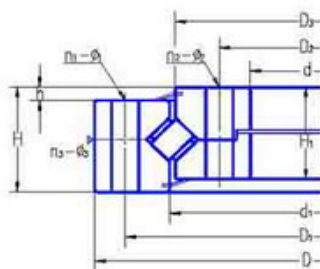

轴承型号 Designation S	外形尺寸 Boundary dimensions			安装孔尺寸 Bolt hole diameter						结构尺寸 Structure dimensions						额定负荷 Basic load ratings Coa 10 ³ N	质量 Mass kg
	D	d	H	D1	D2	n1	n2	φ 1	φ 2	D3	d1	H1	h	n3	φ 3		
mm			mm				mm		mm								
797/1250G2	1608	1250	148	1512	1297	16	16	25	25	1403	1407	128	26	4	M10×1	595	743
797/1250G2K	1608	1250	148	1512	1297	16	16	25	25	1403	1407	128	26	4	M10×1	595	717
797/1278G2K	1660	1278	120	1535	1335	18	18	26	26	1428	1432	105	15	4	M10×1	427	589
797/1320G2	1715	1320	134	—	—	—	—	—	—	1503	1509	—	—	—	—	607	958
797/1370G	1840	1370	160	1770	1430	30	24	28	28	1598	1602	140	10	4	M10×1	997	1213
797/1380G2	1700	1380	145	1650	1440	24	24	27	27	1568	1574	140	5	6	M10×1	461	746
3-944G2	1680	1412	170	—	1460	—	24	—	18	1544	1548	120	25	2	M10×1	617	725
3-944G2K	1680	1412	170	—	1460	—	24	—	18	1544	1548	120	25	2	M10×1	576	723
3-944G2K1	1680	1412	185	—	1460	—	24	—	18	1544	1548	120	25	2	M12×1.25	576	759
797/1600G	2140	1600	145	1940	1710	48	48	26	26	1828	1832	135	10	4	M10×1	896	1357
797/1776G2	2210	1776	150	2105	1840	36	36	26	26	1968	1972	135	15	4	M10×1	1113	1244
797/1860G2	2320	1860	151	2245	1980	42	42	33	33	2113	2117	150	10	6	M10×1	890	1772
797/1916G2	2320	1916	150	2245	1980	42	42	34	34	2113	2117	130	20	3	M10×1	1195	1214
797/2190G	2860	2190	300	2800	2270	36	36	32	32	2530	2550	260	40	12	8	3035	4797
797/2500G2	2980	2500	180	2910	2590	48	48	33	33	2739	2743	170	10	6	M16×1.5	1760	2913
792/2800G	3310	2800	190	3220	2890	60	60	39	39	3050	3060	165	25	2	M10×1	2117	2864

CROSS CYLINDRICAL ROLLER SLEWING BEARING (WITH EXTERNAL GEAR)

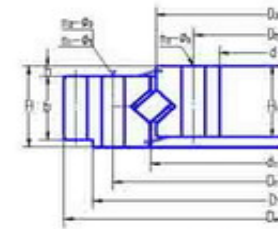
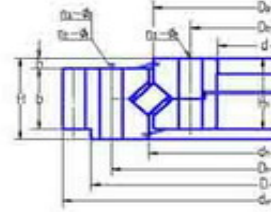
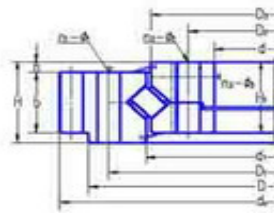

轴承型号 Designations	外形尺寸 Boundary dimensions			安装孔尺寸 Bolt hole diameter				结构尺寸 Structure dimensions						齿轮参数 Gear parameters				额定负荷 Basic load ratings	质量 Mass			
	D mm	d mm	H	D1 mm	D2 mm	n1	n2	φ1 mm	φ2 mm	D3	d1 mm	H1	h	n3	φ3 mm	m	Da mm	Z	b mm	x	Coa 10 ⁴ N	kg
1792/885	1056	885	83	1032	925	16	16	M16	17.5	986	988	75	12.5	—	—	8	1096	135	62.5	0	176	172
E1792/885	1056	885	83	1032	925	16	16	M16	17.5	986	988	75	12.5	—	—	8	1096	135	62.5	0	176	172
E1792/885K	1056	885	83	1032	925	16	16	M16	17.5	986	988	75	12.5	3	M10×1	8	1096	135	62.5	0	176	172
1797/885G	1150	885	115	1115	935	16	16	18	18	1023	1027	100	15	4	M8×1	5	1180	234	80	0	292	330
1797/1100G	1415	1100	115	1345	1160	24	18	21	21	1253	1255	100	15	4	M12×1.25	6	1452	240	84	0	270	497
1798/1100G2	1400	1100	140	1352	1160	26	26	24	26	1260	1264	126	21	4	M10×1	14	1477.28	104	90	-0.24	430	642
1798/1100G2K	1400	1100	145	1352	1160	26	26	24	26	1260	1264	131	26	4	M10×1	14	1477.28	104	90	-0.24	430	644
1797/1250G2	1548	1250	148	1512	1297	16	16	25	25	1403	1407	122	20	4	M10×1	12	1608	132	100	0	539	661
1797/1278G2	1595	1278	120	1535	1335	36	36	26	26	1428	1432	105	15	4	M10×1	12	1655.46	134	90	+1.15	485	597
1797/1300G2	1705	1300	165	1644	1360	24	24	32	32	1504	1508	134	31	4	M10×1	14	1783.6	126	85	-0.3	578	1023
1792/1400G	1715	1400	110	1660	1460	42	42	26	26	1558	1562	95	17	4	M12×1.25	12	1780.8	147	78	-0.3	597	579
1792/1400G2	1715	1400	110	1660	1460	42	42	26	26	1558	1562	95	17	4	M12×1.25	12	1780.8	147	78	-0.3	597	579
1792/1400G2K	1715	1400	110	1660	1460	42	42	26	26	1558	1562	95	15	4	M12×1.25	12	1780.8	147	78	-0.3	597	579
1797/1460G2	1800	1460	125	1735	1525	32	36	26	26	1633	1637	110	10	4	M10×1	14	1881.6	133	95	-0.3	627	828
1797/1460G2K	—	1460	125	1735	1525	32	36	26	26	1633	1637	110	10	4	M10×1	10	1880	186	115	0	627	845
1797/1916G2	—	1916	150	2245	1980	42	42	34	34	2113	2117	130	15	3	M10×1	18	2415.6	133	135	-0.4	1150	1597
1797/2100G2	2600	2100	180	2540	2200	48	48	32	32	2368	2372	158	22	8	M10×1	18	2700	148	130	0	1100	2395
1797/2100G2K	2600	2100	180	2540	2200	48	48	32	32	2368	2372	158	22	8	M10×1	18	2700	148	130	0	1100	2392
1797/2460G2	—	2460	220	2930	2560	30	30	33	34	2745	2747	185	20	30	M12×1.25	14	3108	220	200	0	1386	4091
1797/2460G2U	—	2460	220	2930	2560	30	30	33	34	2745	2747	185	20	30	M12×1.25	14	3108	220	200	0	1386	4091
1797/2460G2K	3108	2460	220	2930	2560	30	30	33	34	2745	2747	200	35	15	ZG1/4in	14	3108	220	200	0	1386	4091
1797/2460G2K1	3108	2460	220	2930	2560	30	30	33	34	2745	2747	200	35	30	ZG1/4in	14	3108	220	200	0	1386	4091

CROSS CYLINDRICAL ROLLER SLEWING BEARING(WITH EXTERNAL GEAR)

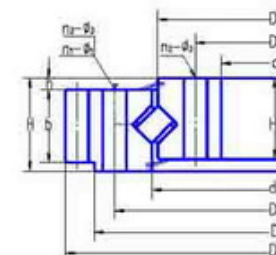
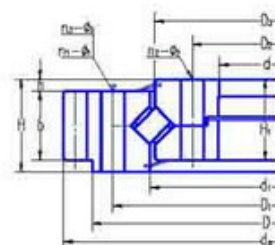
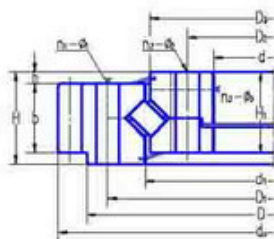

轴承型号 Designations	外形尺寸 Boundary dimensions			安装孔尺寸 Bolt hole diameter				结构尺寸 Structure dimensions						齿轮参数 Gear parameters					额定负荷 Basic load ratings	质量 Mass		
	D	d	H	D1	D2	n1	n2	φ 1	φ 2	D3	d1	H1	h	n3	φ 3	m	Da	Z	b	x	Coa	kg
	mm	mm	mm	mm	mm			mm	mm	mm	mm	mm	mm	mm	mm	mm	mm	mm	mm	mm	10 ⁴ N	
1797/2500G2	—	2500	210	2990	2630	36	36	37	37	2818	2822	200	10	12	M14×1.5	25	3250	128	200	0	1996	4597
1797/2500K	2920	2500	260	3060	2622	36	36	40	40	2949	2916	240	60	36	ZG1/4in	18	3258	179	190	0	1996	5407
1797/2500G2K1	2920	2500	260	3060	2622	36	36	40	40	2949	2916	240	60	36	ZG1/4in	18	3258	179	190	0	1996	5407
1797/2600G	—	2600	200	3050	2700	60	60	35	35	2868	2872	180	20	6	M12×1.25	20	3232.8	160	180	-0.18	2030	3936
1797/2600G2	—	2600	200	3050	2700	60	60	35	35	2868	2872	180	20	18	ZG1/4in	20	3232.8	160	180	-0.18	2030	3936
1797/2600G2K	—	2600	200	3050	2700	60	60	35	35	2868	2872	180	20	4	14	20	3232.8	160	180	-0.18	2030	3936
1797/2600G2K1	—	2600	200	3050	2700	60	60	35	35	2868	2872	180	20	8	M10×1	20	3232.8	160	180	-0.18	2320	3558
1797/2635G	3332	2635	270	3240	2755	36	36	42	42	2998	3002	240	45	6	M12×1.25	20	3440	170	200	0	2950	5973
1797/2635G2	3332	2635	270	3240	2755	36	36	42	42	2998	3002	225	30	12	ZG1/4in	20	3440	170	200	0	2950	5973
1797/3230G	3970	3230	240	3820	3350	52	54	37	37	3578	3582	220	20	9	M12×1.25	25	4100	162	200	0	3520	7612
1797/3230GY	3970	3230	240	3820	3380	52	36	37	37	3578	3582	220	20	4	M12×1.25	25	4100	162	200	0	3520	7612
1797/3230G2	3970	3230	240	3820	3350	52	54	37	37	3578	3582	220	20	9	M12×1.25	25	4100	162	200	0	3520	7613
1797/3230G2K	3970	3230	240	3820	3350	52	54	37	37	3578	3582	220	20	8	14	25	4100	162	200	0	3520	7613
1797/3230GK5	3970	3230	240	3820	3350	52	54	37	37	3578	3582	220	20	4	M12×1.25	25	4100	162	200	0	3520	7613
1797/3230G2Y3K	—	3230	240	3820	3380	52	36	37	37	3578	3582	220	20	4	M12×1.25	25	4100	162	220	0	3520	7686
1797/3760G	4220	3760	240	4160	3840	48	48	32	32	3996	4004	210	55	4	M14×1.5	14	4326	307	135	0	3210	4396
1797/4250G	4940	4250	250	4840	4350	72	72	48	48	4598	4602	225	25	9	M16×1.5	30	5082	168	200	-0.3	4520	8954

CROSS CYLINDRICAL ROLLER SLEWING BEARING

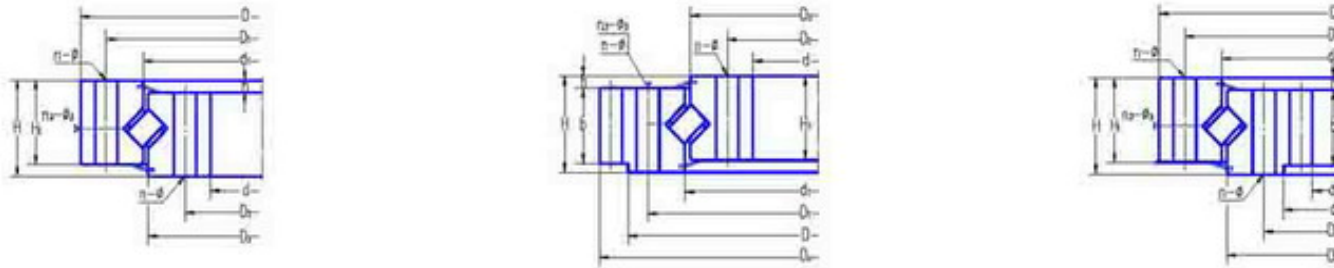

轴承型号 Designations			外形尺寸 Boundary dimensions			安装孔尺寸 Bolt hole diameter				结构尺寸 Structure dimensions					齿轮参数 Gear parameters					额定负荷 Basic load ratings	质量 Mass			
无齿式 non-gear type	外齿式 external gear type	内齿式 internal gear type	D	d	H	D1	D2	n	φ	D3	d1	H1	h	n3	φ3	m	Da	Z	da	Z	b	x	C _{0a} 10 ⁴ N	kg
			mm			mm				mm														
110-40-2000**	111-40-2000**	113-40-2000**	2178	1825	112	2110	1891	48	33	1998	2002	100	12	8	M10×1	16	2272	139	1728	109	90	0.5	686	900
	112-40-2000**	114-40-2000**	2178	1825	112	2110	1891	48	33	1998	2002	100	12	8	M10×1	18	2268	123	1728	97	90	0.5	686	900
110-40-2000-12			2178	1825	112	2110	1891	48	33	1991	1995	100	12	8	M10×1	—	—	—	—	—	—	—	635	767
110-40-2240**	111-40-2240**	113-40-2240**	2418	2065	112	2350	2131	48	33	2237.5	2242.5	100	12	8	M10×1	16	2496	153	1984	125	90	0.5	764	1000
	112-40-2240**	114-40-2240**	2418	2065	112	2350	2131	48	33	2237.5	2242.5	100	12	8	M10×1	18	2502	136	1980	111	90	0.5	764	1000
110-40-2500**	111-40-2500**	113-40-2500**	2678	2325	112	2610	2391	56	33	2497.5	2502.5	100	12	8	M10×1	18	2772	151	2232	125	90	0.5	797	876
	112-40-2500**	114-40-2500**	2678	2325	112	2610	2391	56	33	2497.5	2502.5	100	12	8	M10×1	20	2780	136	2220	112	90	0.5	797	876
	112-40-2500-12K		2678	2325	112	2610	2391	56	33	2498.5	2501.5	100	112	8	M16×1.5	—	—	—	—	—	—	—	1000	876
110-40-2800**	111-40-2800**	113-40-2800**	2978	2625	112	2910	2691	56	33	2797.5	2802.5	100	12	8	M10×1	18	3078	168	2520	141	90	0.5	960	1250
	112-40-2800**	114-40-2800**	2978	2625	112	2910	2691	56	33	2797.5	2802.5	100	12	8	M10×1	20	3080	151	2520	127	90	0.5	960	1250
110-50-3150**	111-50-3150**	113-50-3150**	3376	2922	134	3286	3014	56	45	3147.5	3152.5	122	12	8	M10×1	20	3480	171	2820	142	110	0.5	1380	2150
	112-50-3150**	114-50-3150**	3376	2922	134	3286	3014	56	45	3147.5	3152.5	122	12	8	M10×1	22	3476	155	2816	129	110	0.5	1380	2150
110-50-3550**	111-50-3550**	113-50-3550**	3776	3322	134	3686	3414	56	45	3547.5	3552.5	122	12	8	M10×1	20	3880	191	3220	162	110	0.5	1570	2470
	112-50-3550**	114-50-3550**	3776	3322	134	3686	3414	56	45	3547.5	3552.5	122	12	8	M10×1	22	3894	174	3212	147	110	0.5	1570	2470
	111-52-3550-12		3776	3322	134	3686	3414	56	45	3548	3552	122	12	8	M10×1	20	3880	191	—	—	110	0.5	1475	2464
110-50-4000**	111-50-4000**	113-50-4000**	4226	3772	134	4136	3864	60	45	3997.5	4002.5	122	12	10	M10×1	22	4334	194	3652	167	110	0.5	1760	2800
	112-50-4000**	114-50-4000**	4226	3772	134	4136	3864	60	45	3997.5	4002.5	122	12	10	M10×1	25	4350	171	3650	147	110	0.5	1760	2800
110-50-4500**	111-50-4500**	113-50-4500**	4726	4272	134	4636	4364	60	45	4497.5	4502.5	122	12	10	M10×1	22	4940	217	4158	190	110	0.5	1980	3100
	112-50-4500**	114-50-4500**	4726	4272	134	4636	4364	60	45	4497.5	4502.5	122	12	10	M10×1	25	4850	191	4150	167	110	0.5	1980	3100

CROSS TAPERED ROLLER SLEWING BEARING

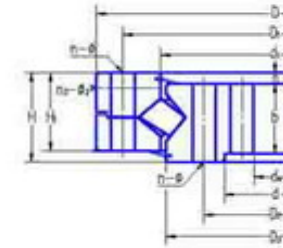
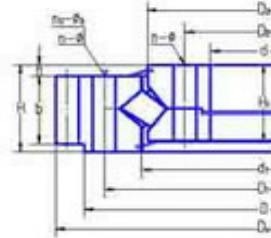
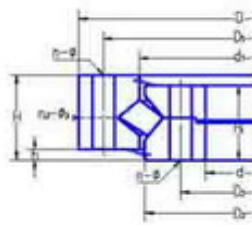

轴承型号 Designations			外形尺寸 Boundary dimensions			安装孔尺寸 Bolt hole diameter				结构尺寸 Structure dimensions					齿轮参数 Gear parameters					额定负荷 Basic load ratings	质量 Mass			
无齿式 non-gear type	外齿式 external gear type	内齿式 internal gear type	D	d	H	D1	D2	n	φ	D3	d1	H1	h	n3	φ3	m	Da	Z	da	Z	b	x	Coa	kg
			mm			mm				mm										10 ⁴ N				
5792/900		3-935G 7797/1660G	1150	900	90	1105	950	24	19	1021	1025	78	12	6	M8×1	—	—	—	—	—	—	—	165	227
			940	—	90	900	752	24	19 17	823	827	78	12	6	M8×1	4	—	—	672	170	78	0	133	180
			2150	1660	245	2100	1735	30	32	1909	1921	220	25	3	M10×1	16	—	—	1581.12	100	190	+0.35	996	2194
120-25-500**	121-25-500**	123-25-500**	602	398	75	566	434	20	18	498.5	501.5	65	10	4	M10×1	5	630	123	365	74	60	+0.5	104	80
	122-25-500**	124-25-500**	602	398	75	566	434	20	18	498.5	501.5	65	10	4	M10×1	6	630	102	366	62	60	+0.5	104	80
120-25-560**	121-25-560**	123-25-560**	662	458	75	626	494	20	18	558.5	561.5	65	10	4	M10×1	5	690	135	425	86	60	+0.5	116	90
	122-25-560**	124-25-560**	662	458	75	626	494	20	18	558.5	561.5	65	10	4	M10×1	6	690	112	426	72	60	+0.5	116	90
120-25-630**	121-25-630**	123-25-630**	732	528	75	696	564	24	18	628.5	631.5	65	10	4	M10×1	6	774	126	492	83	60	+0.5	130	100
	122-25-630**	124-25-630**	732	528	75	696	564	24	18	628.5	631.5	65	10	4	M10×1	8	776	94	488	62	60	+0.5	130	100
120-25-710**	121-25-710**	123-25-710**	812	608	75	776	644	24	18	708.5	712.5	65	10	4	M10×1	6	852	139	570	96	60	+0.5	149	110
	122-25-710**	124-25-710**	812	608	75	776	644	24	18	708.5	712.5	65	10	4	M10×1	8	856	104	568	72	60	+0.5	149	110
120-28-800**	121-28-800**	123-28-800**	922	678	82	878	722	30	22	798.5	801.5	72	10	6	M10×1	8	968	118	632	80	65	+0.5	185	170
	122-28-800**	124-28-800**	922	678	82	878	722	30	22	798.5	801.5	72	10	6	M10×1	10	970	94	630	64	65	+0.5	185	170
120-28-900**	121-28-900**	123-28-900**	1022	778	82	978	822	30	22	898.5	901.5	72	10	6	M10×1	8	1064	130	736	93	65	+0.5	209	190
	122-28-900**	124-28-900**	1022	778	82	978	822	30	22	898.5	901.5	72	10	6	M10×1	10	1070	104	730	74	65	+0.5	209	190
120-28-1000**	121-28-1000**	123-28-1000**	1122	878	82	1078	922	36	22	998.5	1001.5	72	10	6	M10×1	10	1190	116	820	83	65	+0.5	233	210
	122-28-1000**	124-28-1000**	1122	878	82	1078	922	36	22	998.5	1001.5	72	10	6	M10×1	12	1188	96	816	69	65	+0.5	233	210
120-28-1120**	121-28-1120**	123-28-1120**	1242	998	82	1198	1042	36	22	1118	1122	72	10	6	M10×1	10	1300	127	940	95	65	+0.5	262	230
	122-28-1122**	124-28-1120**	1242	998	82	1198	1042	36	22	1118	1122	72	10	6	M10×1	12	1308	106	936	79	65	+0.5	262	230
120-32-1250**	121-32-1250**	123-32-1250**	1390	1110	91	1337	1163	40	26	1248	1252	81	10	6	M10×1	12	1452	118	1044	88	75	+0.5	321	350
	122-32-1250**	124-32-1250**	1390	1110	91	1337	1163	40	26	1248	1252	81	10	6	M10×1	14	1456	101	1036	75	75	+0.5	321	350
120-32-1400**	121-32-1400**	123-32-1400**	1540	1260	91	1487	1313	40	26	1398	1402	81	10	6	M10×1	12	1608	131	1188	100	75	+0.5	358	400
	122-32-1400**	124-32-1400**	1540	1260	91	1487	1313	40	26	1398	1402	81	10	6	M10×1	14	1610	112	1190	86	75	+0.5	358	400

CROSS CYLINDRICAL ROLLER SLEWING BEARING(WITH INTERNAL GEAR)

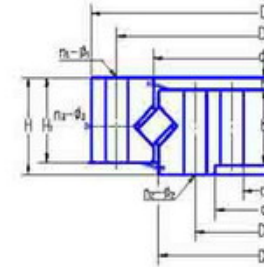
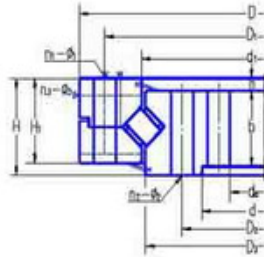

轴承型号 Designation s	外形尺寸 Boundary dimensions			安装孔尺寸 Bolt hole diameter						结构尺寸 Structure dimensions						齿轮参数 Gear parameters					额定负荷 Basic load ratings	质量 Mass
	D	d mm	H	D1 mm	D2 mm	n1	n2	φ1 mm	φ2 mm	D3	d1 mm	H1	h	n3	φ3 mm	m	da mm	Z	b mm	x	Coa 10 ³ N	kg
2797/695G2	920	695	90	870	735	30	30	18	18	800	804	76	4	3	10	7	658	96	65	0	161	175
2797/760G2	1000	760	95	956	800	24	24	20	20	878	882	82	15	4	M10×1	8	718.18	91	70	0.35	237	206
2797/870G2	1180	870	115	1125	920	18	18	26	26	1023	1027	100	15	2	M8×1	8	828.8	105	90	0.3	292	374
2797/875G2	1170	875	95	1120	930	24	24	22	22	1018	1022	82	15	4	M10×1	8	830.1	105	70	0.35	276	297
2797/955G	1200	95	90	1160	1000	36	18	18	18	1088	1092	76	10	4	M8×1	8	908.8	115	72	0.3	254	245
2797/955G2	1200	95	90	1160	1000	36	18	18	18	1088	1092	76	10	4	M8×1	8	908.8	115	72	0.3	254	245
2797/1010G2	1200	1010	90	1160	1041	36	20	22	M20	1088	1092	76	10	2	M8×1	10	962	97	72	0.6	254	199
2797/1010GK	1200	1010	90	1160	1041	36	20	22	M20	1088	1092	76	10	2	M8×1	10	962	97	72	0.6	254	199
2797/1278G2	1595	1278	120	1535	1335	36	36	26	26	1428	1432	106	14	6	M10×1	12	1221.14	103	90	0.35	398	585
2792/1400G2K	1715	1400	110	1660	1460	40	40	26	M24	1558	1562	95	15	4	M10×1	10	1330	135	90	0	597	587
2792/2000G2	2420	2000	160	2350	2070	48	48	33	M30	2207	2213	140	20	6	M10×1	14	1913.5	138	120	0.3	1084	1607
2792/2240G	2670	2240	160	2600	2320	54	54	35	M36	2457	2463	140	20	6	M12×1.25	16	2154.5	136	120	0.3	1441	1798
3-940G	2800	2300	208	2710	2390	42	48	38	M36	2535	2545	180	18	6	M10×1	20	2162.75	110	175	0	1743	2756
2797/2680G	3325	2680	300	3242	2754	32	32	33	33	2996	3000	270	30	4	M16×1.5	16	2592	164	180	0	3587	6320
2797/2680GY	3325	2680	300	3242	2754	48	48	33	33	2996	3000	270	30	4	M16×1.5	16	2592	164	180	0	3587	6320
2797/2680GK	3325	2680	300	3242	2754	32	32	33	33	2996	3000	270	30	4	M16×1.5	16	2592	164	180	0	3035	6641
3-943G2	3850	3322	200	3720	3420	60	60	45	45	3568	3572	180	20	12	Z1/4in	22	3206.368	147	158	0.35	1806	4520

CROSS CYLINDRICAL ROLLER SLEWING BEARING

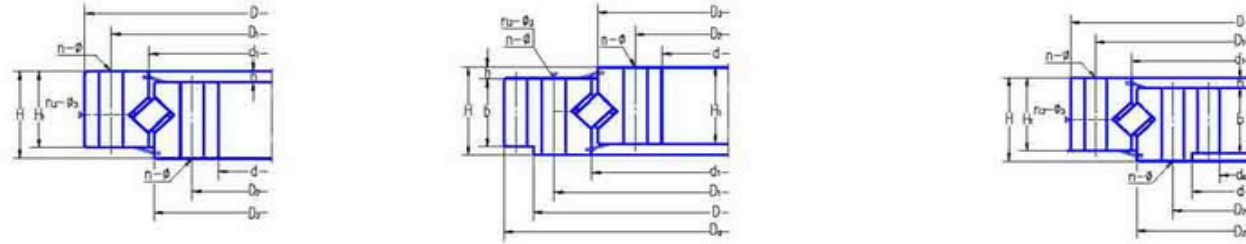

轴承型号 Designations			外形尺寸 Boundary dimensions			安装孔尺寸 Bolt hole diameter				结构尺寸 Structure dimensions					齿轮参数 Gear parameters					额定负荷 Basic load ratings	质量 Mass							
无齿式 non-gear type	外齿式 external gear type	内齿式 internal gear type	D	d	H	D1	D2	n	φ	D3	d1	H1	h	n3	φ3	m	Da	Z	da	Z	b	x	Coa	kg				
			mm			mm			mm	mm					mm	mm	mm	mm	mm	mm	mm	mm	mm	mm	mm	mm	mm	mm
110-25-500**	111-25-500** 112-25-500**	113-25-500** 114-25-500**	602	398	75	566	434	20	18	499	501	65	10	4	M10×1	5	630	123	365	74	60	0.5	104	80				
110-25-560**	111-25-560** 112-25-560**	113-25-560** 114-25-560**	662	458	75	626	494	20	18	558.5	561.5	65	10	4	M10×1	5	690	135	425	86	60	0.5	116	90				
110-25-630**	111-25-630** 112-25-630**	113-25-630** 114-25-630**	732	528	75	696	564	24	18	628.5	631.5	65	10	4	M10×1	6	774	126	492	83	60	0.5	130	100				
110-25-710**	111-25-710** 112-25-710**	113-25-710** 114-25-710**	812	608	75	776	644	24	18	708.5	711.5	65	10	4	M10×1	6	852	139	570	96	60	0.5	149	110				
110-28-800**	111-28-800** 112-28-800**	113-28-800** 114-28-800**	922	678	82	878	722	30	22	798.5	801.5	72	10	6	M10×1	8	968	118	632	80	65	0.5	185	170				
110-28-900**	111-28-900** 112-28-900**	113-28-900** 114-28-900**	1022	778	82	978	822	30	22	898.5	901.5	72	10	6	M10×1	8	1064	130	736	93	65	0.5	209	190				
110-28-1000**	111-28-1000** 112-28-1000**	113-28-1000** 114-28-1000**	1122	878	82	1078	922	36	22	998.5	1001.5	72	10	6	M10×1	10	1190	116	820	83	65	0.5	233	210				
110-28-1120**	111-28-1120** 112-28-1120**	113-28-1120** 114-28-1120**	1242	998	82	1198	1042	36	22	1118	1122	72	10	6	M10×1	10	1300	127	940	95	65	0.5	262	230				
110-32-1250**	111-32-1250** 112-32-1250**	113-32-1250** 114-32-1250**	1390	1110	91	1337	1163	40	26	1248	1252	81	10	6	M10×1	12	1452	118	1044	88	75	0.5	321	350				
110-32-1400**	111-32-1400** 112-32-1400**	113-32-1400** 114-32-1400**	1540	1260	91	1487	1313	40	26	1398	1402	81	10	6	M10×1	12	1608	131	1188	100	75	0.5	358	400				
110-32-1600**	111-32-1600** 112-32-1600**	113-32-1600** 114-32-1600**	1740	1460	91	1687	1513	45	26	1598	1602	81	10	8	M10×1	14	1820	127	1386	100	75	0.5	412	440				
110-32-1800**	111-32-1800** 112-32-1800**	113-32-1800** 114-32-1800**	1940	1660	91	1887	1713	45	26	1798	1802	81	10	8	M10×1	14	2016	141	1568	113	75	0.5	460	500				
		113-45-1830-11	2002	1665	156	1940	1720	54	30	1827	1833	128	28	6	M10×1	12	--	--	1610	135	100	0.5	571	912				

CROSS TAPERED ROLLER SLEWING BEARING

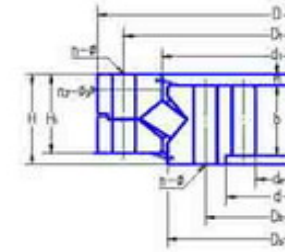
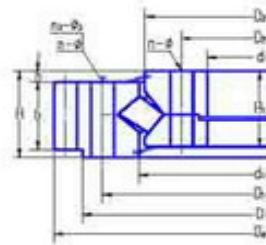
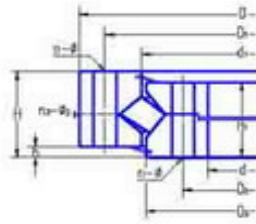

轴承型号 Designations			外形尺寸 Boundary dimensions			安装孔尺寸 Bolt hole diameter				结构尺寸 Structure dimensions					齿轮参数 Gear parameters						额定负荷 Basic load ratings	质量 Mass			
无齿式 non-gear type	外齿式 external gear type	内齿式 internal gear type	D	d	H	D1	D2	n	φ	D3	d1	H1	h	n3	φ3	m	Da	Z	da	Z	b	x	Coa	10 ⁴ N	kg
			mm			mm				mm															
120-32-1600-***	121-32-1600-***	123-32-1600-***	1740	1460	91	1687	1513	45	26	1598	1602	81	10	8	M10×1	14	1820	127	1386	100	75	+0.5	412	440	
	122-32-1600-***	124-32-1600-***	1740	1460	91	1687	1513	45	26	1598	1602	81	10	8	M10×1	16	1824	111	1376	87	75	+0.5	412	440	
120-32-1600-03K			1740	1460	100	1687	1513	48	26	1598	1602	90	10	8	M10×1	—	—	—	—	—	—	—	—	469	429
120-32-1800-***	121-32-1800-***	123-32-1800-***	1940	1660	91	1887	1713	45	26	1798	1802	81	10	8	M10×1	14	2016	141	1568	113	75	+0.5	460	500	
	122-32-1800-***	124-32-1800-***	1940	1660	91	1887	1713	45	26	1798	1802	81	10	8	M10×1	16	2016	123	1568	99	75	+0.5	460	500	
120-40-2000-***	121-40-2000-***	123-40-2000-***	2178	1825	112	2110	1891	48	33	1998	2002	100	12	8	M10×1	16	2272	139	1728	109	90	+0.5	686	900	
	122-40-2200-***	124-40-2000-***	2178	1825	112	2110	1891	48	33	1998	2002	100	12	8	M10×1	18	2268	123	1728	97	90	+0.5	686	900	
120-40-2240-***	121-40-2240-***	123-40-2240-***	2418	2065	112	2350	2131	48	33	2237.5	2242.5	100	12	8	M10×1	16	2496	153	1984	125	90	+0.5	764	1000	
	122-40-2240-***	124-40-2240-***	2418	2065	112	2350	2131	48	33	2237.5	2242.5	100	12	8	M10×1	18	2502	136	1980	111	90	+0.5	764	1000	
120-40-2500-***	121-40-2500-***	123-40-2500-***	2678	2325	112	2610	2391	56	33	2497.5	2502.5	100	12	8	M10×1	18	2772	151	2232	125	90	+0.5	852	1100	
	122-40-2500-***	124-40-2500-***	2678	2325	112	2610	2391	56	33	2497.5	2502.5	100	12	8	M10×1	20	2780	136	2220	112	90	+0.5	852	1100	
120-40-2800-***	121-40-2800-***	123-40-2800-***	2978	2625	112	2910	2691	56	33	2797.5	2802.5	100	12	8	M10×1	18	3078	168	2520	141	90	+0.5	960	1250	
	122-40-2800-***	124-40-2800-***	2978	2625	112	2910	2691	56	33	2797.5	2802.5	100	12	8	M10×1	20	3080	151	2520	127	90	+0.5	960	1250	
120-50-3150-***	121-50-3150-***	123-50-3150-***	3376	2922	134	3286	3014	56	45	3147.5	3152.5	122	12	8	M10×1	20	3480	171	2820	142	110	+0.5	1380	2150	
	122-50-3150-***	124-50-3150-***	3376	2922	134	3286	3014	56	45	3147.5	3152.5	122	12	8	M10×1	22	3476	155	2816	129	110	+0.5	1380	2150	
120-50-3550-***	121-50-3550-***	123-50-3550-***	3776	3322	134	3686	3414	56	45	3547.5	3552.5	122	12	8	M10×1	20	3880	191	3220	162	110	+0.5	1570	2470	
	122-50-3550-***	124-50-3550-***	3776	3322	134	3686	3414	56	45	3547.5	3552.5	122	12	8	M10×1	22	3894	174	3212	147	110	+0.5	1570	2470	
120-50-4000-***	121-50-4000-***	123-50-4000-***	4226	3772	134	4136	3864	60	45	3997.5	4002.5	122	12	10	M10×1	22	4334	194	3652	167	110	+0.5	1760	2800	
	122-50-4000-***	124-50-4000-***	4226	3772	134	4136	3864	60	45	3997.5	4002.5	122	12	10	M10×1	25	4350	171	3650	147	110	+0.5	1760	2800	
120-50-4500-***	121-50-4500-***	123-50-4500-***	4726	4272	134	4636	4364	60	45	4497.5	4502.5	122	12	10	M10×1	22	4840	217	4158	190	110	+0.5	1980	3100	
	122-50-4500-***	124-50-4500-***	4726	4272	134	4636	4364	60	45	4497.5	4502.5	122	12	10	M10×1	25	4850	191	4150	167	110	+0.5	1980	3100	

THREE-ROW CYLINDRICAL ROLLER COMBINED SLEWING BEARING

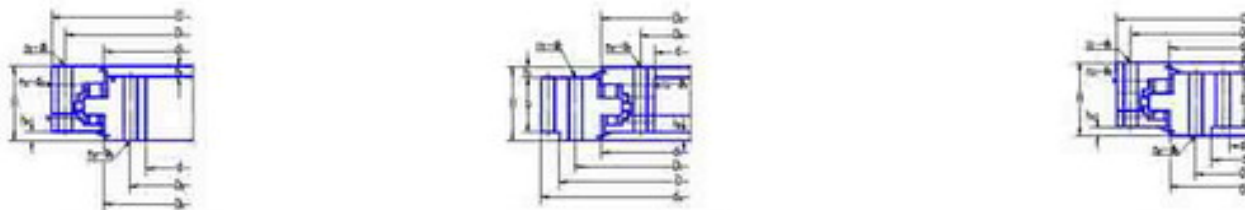

轴承型号 Designations	外形尺寸 Boundary dimensions			安装孔尺寸 Bolt hole diameter						结构尺寸 Structure dimensions							齿轮参数 Gear parameters					额定负荷 Basic load ratings		质量 Mass		
	D	d	H	D1	D2	n1	n2	φ1	φ2	D3	d1	D3'	d1'	h1	h2	n3	φ3	m	da	Z	b	x	Coa		Cor	kg
UNGEARED																										
3-931G	4300	3850	355	4210	3750	90	90	48	48	-	-	3850	3860	-	-	18	M16×1.5	-	-	-	-	-	9570	1330	9503	
WITH EXTERNAL GEAR																										
6397/1605G2K	1884	1605	250	1932	1657	36	48	26	26	1850	1858	-	-	50	33	6×3	M14×1.5	16	2054	127	170	0	1525	208	1800	
3-947G	2465	1850	258	2390	2020	60	60	39	39	2261	2247	-	-	46	20	6×2	M10×1	18	2554	139	180	+0.5	2253	320	3515	
3-934G	2650	2240	180	2588	2300	54	54	34	34	2487	2482	-	-	30	15	6×3	M14×1.5	18	2854	150	132	+0.5	1680	205	1832	
6397/2590	3006	2590	200	2930	2670	60	60	39	39	2845	2860	-	-	21	20	10×3	M10×1	16	3086	190	95	+0.4375	2192	316	2780	
6397/2590K	3006	2590	314	2930	2670	60	60	39	39	2860	2884	-	-	19	24	10×3	M10×1	16	3095	190	134	+0.4375	2700	316	4209	
6397/2800G	3260	2800	220	3190	2870	60	60	39	39	3082	3068	-	-	30	18	6×3	M14×1.5	20	3360	166	160	0	2700	330	3288	
6397/2800GK	3255	2800	240	3185	2870	48	64	39	39	3082	3068	-	-	30	38	6×3	M14×1.5	18	3348	184	160	0	2700	330	3419	
6397/2800GK1	3255	2800	240	3185	2870	64	64	39	M36	3082	3068	-	-	30	38	6×3	M14×1.5	18	3348	184	180	0	2700	330	3429	
6397/2800GK2	3255	2800	240	3185	2870	48	64	39	M36×3	3082	3068	-	-	30	32	6×3	M14×1.5	18	3348	184	160	0	2700	330	3424	
6392/2910G	3400	2910	220	3315	2990	56	56	39	39	3200	3187	-	-	50	10	8×2	M14×1.5	22	3520	156	160	0	2670	458	3736	
6397/3340	3888	3340	212	3735	3441	108	108	33	33	3842	3612	-	-	42	22	24	Z1/4in	24	3888	161	170	+0.5	3900	410	3684	
WITH INTERNAL GEAR																										
7397/2210K	2650	2216	220	2590	2276	56	40	M30	33	-	-	2380	2382	27	23	8×3	M10×1	16	2130	135	140	0	2050	302	2418	
7397/2700G2	3150	2700	255	3070	2750	40	70	32	32	-	-	2656	2652	40	30	4×2	M14×1.5	20	2609	132	180	0	2920	423	3536	
7397/2700G2K	3150	2700	255	3070	2750	72	72	32	32	-	-	2656	2652	40	30	6×2	ZG 1/4in	20	2604	132	180	0	2920	423	3542	
7397/2700GK1	3150	2700	255	3070	2755	76	80	38	38	-	-	2656	2652	40	30	4×2	M14×1.5	20	2609	132	180	0	2920	423	3393	
7397/2700G2K2	3150	2700	255	3070	2750	72	72	33	33	-	-	2662	2652	40	30	6×2	ZG 1/4in	20	2604	132	180	0	2920	423	3542	
7397/2700G2K3	3150	2700	255	3070	2750	8	2	32	M30	-	-	2656	2652	40	30	4×2	M14×1.5	20	2609	132	180	0	2920	423	3699	
3-945G2	5000	4190	430	4880	4310	66	72	44	44	-	-	4482	4410	49	30	12×2	M10×1	25	4088	164	240	+0.35	10506	1116	14204	

THREE-ROW CYLINDRICAL ROLLER COMBINED SLEWING BEARING

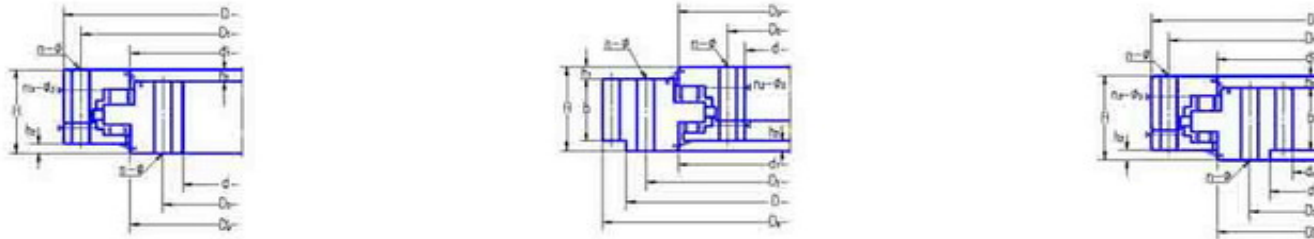

轴承型号 Designations			外形尺寸 Boundary dimensions			安装孔尺寸 Bolt hole diameter			结构尺寸 Structure dimensions					齿轮参数 Gear parameters				额定负荷 Basic load ratings		质量 Mass						
无齿式 non-gear type	外齿式 external gear type	内齿式 internal gear type	D	d	H	D1	D2	n	φ	D3	d1	h1	h2	n3	φ3	a	Da	Z	da	Z	b	x	Coa	Cor	10 ⁴ N	kg
130-25-500**	131-25-500**	133-25-500**	634	366	148	598	402	24	18	537	526	32	10	4×2	M10×1	5	665	130	335	68	80	+0.5	275	35.5	224	
	132-25-500**	134-25-500**	634	366	148	598	402	24	18	474	463	32	10	4×2	M10×1	6	666	108	336	57	80	+0.5	275	35.5	224	
130-25-560**	131-25-560**	133-25-560**	694	426	148	658	462	24	18	597	586	32	10	4×2	M10×1	5	725	142	395	80	80	+0.5	308	39.9	240	
	132-25-560**	134-25-560**	694	426	148	658	462	24	18	534	523	32	10	4×2	M10×1	6	726	118	396	67	80	+0.5	308	39.9	240	
130-25-630**	131-25-630**	133-25-630**	764	496	148	728	532	28	18	667	656	32	10	4×2	M10×1	6	810	132	456	77	80	+0.5	345	45.1	270	
	132-25-630**	134-25-630**	764	496	148	728	532	28	18	(604)	(593)	32	10	4×2	M10×1	8	808	98	456	58	60	+0.5	345	45.1	270	
130-25-710**	131-25-710**	133-25-710**	844	576	148	808	612	28	18	747	736	32	10	4×2	M10×1	6	888	145	534	90	80	+0.5	388	51.7	300	
	132-25-710**	134-25-710**	844	576	148	808	612	28	18	(684)	(673)	32	10	4×2	M10×1	8	888	108	536	68	80	+0.5	388	51.7	300	
130-32-800**	131-32-800**	133-32-800**	964	636	182	920	680	36	22	841	830	40	10	4×2	M10×1	8	1008	123	592	75	120	+0.5	549	71.2	500	
	132-32-800**	134-32-800**	964	636	182	920	680	36	22	(770)	759	40	10	4×2	M10×1	10	1010	98	590	60	120	+0.5	549	71.2	500	
130-32-900**	131-32-900**	133-32-900**	1064	736	182	1020	780	36	22	941	930	40	10	4×2	M10×1	8	1104	135	688	87	120	+0.5	619	80.8	600	
	132-32-900**	134-32-900**	1064	736	182	1020	780	36	22	(870)	(859)	40	10	4×2	M10×1	10	1110	108	690	70	120	+0.5	619	80.8	600	
130-32-1000**	131-32-1000**	133-32-1000**	1164	836	182	1120	880	40	22	1041	1030	40	10	5×2	M10×1	10	1220	119	780	79	120	+0.5	689	90.3	680	
	132-32-1000**	134-32-1000**	1164	836	182	1120	880	40	22	(970)	(959)	40	10	5×2	M10×1	12	1224	99	780	66	120	+0.5	689	90.3	680	
130-32-1120**	131-32-1120**	133-32-1120**	1284	956	182	1240	1000	40	22	1161	1150	40	10	5×2	M10×1	10	1340	131	900	91	120	+0.5	768	102	820	
	132-32-1120**	134-32-1120**	1284	956	182	1240	1000	40	22	(1090)	(1079)	40	10	5×2	M10×1	12	1344	109	900	76	120	+0.5	768	102	820	
130-40-1250**	131-40-1250**	133-40-1250**	1445	1055	220	1393	1107	45	26	1300	1290	50	10	5×2	M10×1	12	1512	123	984	83	150	+0.5	1110	146	1200	
	132-40-1250**	134-40-1250**	1445	1055	220	1393	1107	45	26	(1210)	(1200)	50	10	5×2	M10×1	14	1512	105	980	71	150	+0.5	1110	146	1200	

THREE-ROW CYLINDRICAL ROLLER COMBINED SLEWING BEARING

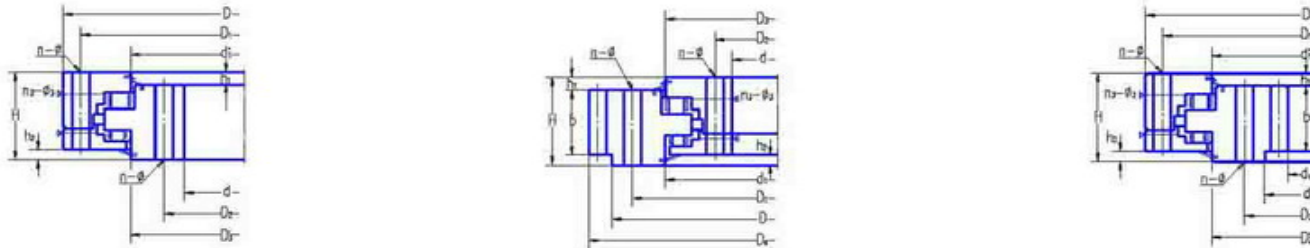

轴承型号 Designations			外形尺寸 Boundary dimensions		安装孔尺寸 Bolt hole diameter		结构尺寸 Structure dimensions						齿轮参数 Gear parameters			额定负荷 Basic load ratings		质量 Mass								
无齿式 non-gear type	外齿式 external gear type	内齿式 internal gear type	D	d	H	D1	D2	n	φ	D3	d1	h1	h2	n3	φ3	m	Da	Z	da	Z	b	x	Coa	Cor	10 ⁴ N	kg
			mm		mm		mm		mm		mm		mm		mm		mm		mm							
130 40 1400 **	131 40 1400 **	133 40 1400 **	1595	1205	220	1543	1257	45	26	1450	1440	50	10	5×2	M10×1	12	1668	136	1140	96	150	+0.5	1240	165	1300	
	132 40 1400 **	134 40 1400 **	1595	1205	220	1543	1257	45	26	(1360)	(1350)	50	10	5×2	M10×1	14	1666	116	1134	80	150	+0.5	1240	165	1300	
	130 40 1600 **	131 40 1600 **	133 40 1600 **	1795	1405	220	1743	1457	48	26	1650	1640	50	10	6×2	M10×1	14	1876	131	1330	96	150	+0.5	1420	190	1520
130 40 1800 **	132 40 1800 **	134 40 1800 **	1795	1405	220	1743	1457	48	26	(1560)	(1550)	50	10	6×2	M10×1	16	1872	114	1328	84	150	+0.5	1420	190	1520	
	130 40 1800 **	131 40 1800 **	1995	1605	220	1943	1657	48	26	1850	1840	50	10	6×2	M10×1	14	2072	145	1526	110	150	+0.5	1590	215	1750	
	132 40 1800 **	134 40 1800 **	1995	1605	220	1943	1657	48	26	(1760)	(1750)	50	10	6×2	M10×1	16	2080	127	1520	96	150	+0.5	1590	215	1750	
130 45 2000 **	131 25 2000 03		2195	1816	150	2127	1885	60	33		2041	33	13	3×5	ZG1/4in	16	2267	138	-	-	105	+0.9	1690	60.3	1120	
	131 45 2000 04		2221	1779	231	2155	1845	60	33	2059	2055	54	12	6×3	M10×1	16	2304	141	1696	107	160	+0.5	2050	239	2230	
	131 45 2000 **	133 45 2000 **	2221	1779	231	2155	1845	60	33	2055	2033	54	12	6×2	M10×1	16	2304	141	1696	107	160	+0.5	2050	239	2400	
130 45 2240 **	132 45 2000 **	134 45 2000 **	2221	1779	231	2155	1845	60	33	(1967)	(1945)	54	12	6×2	M10×1	18	2304	125	1692	95	160	+0.5	2050	239	2400	
	131 45 2240 **	133 45 2240 **	2461	2019	231	2395	2085	60	33	2295	2273	54	12	6×2	M10×1	16	2560	157	1920	121	160	+0.5	2310	268	2700	
	132 45 2240 **	134 45 2240 **	2461	2019	231	2395	2085	60	33	(2207)	(2185)	54	12	6×2	M10×1	18	2556	139	1926	108	160	+0.5	2310	268	2700	
130 45 2500 **	131 45 2500 04		2721	2279	231	2655	2345	72	33	2555	2581	54	12	8×3	M10×1	18	2826	154	-	-	160	+0.5	2580	302	2834	
	131 45 2500 **	133 45 2500 **	2721	2279	231	2655	2345	72	33	2555	2533	54	12	8×2	M10×1	18	2826	154	2178	122	160	+0.5	2580	302	3000	
	132 45 2500 **	134 45 2500 **	2721	2279	231	2655	2345	72	33	(2467)	(2445)	54	12	8×2	M10×1	20	2820	138	2180	110	160	+0.5	2580	302	3000	
130 45 2800 **	131 45 2800 **	133 45 2800 **	3021	2579	231	2955	2645	72	33	2855	2833	54	12	8×2	M10×1	18	3114	170	2484	139	160	+0.5	2880	339	3400	
	132 45 2800 **	134 45 2800 **	3021	2579	231	2955	2645	72	33	(2767)	(2745)	54	12	8×2	M10×1	20	3120	153	2480	125	160	+0.5	2880	339	3400	
	132 45 2800 03		3021	2579	231	2955	2645	72	33	2855	2833	54	12	8×3	M10×1	20	3120	153	-	-	160	+0.5	2896	323	3031	
130 50 3150 **	132 45 2800 12		3021	2579	231	2955	2645	72	33	2855	2833	54	12	8×3	M10×1	18	3114	170	-	-	160	+0.5	2896	323	3010	
	131 50 3150 **	133 50 3150 **	3432	2868	270	3342	2958	72	45	3213	3196	65	12	8×2	M10×1	20	3540	174	2760	139	180	0.5	3590	381	5000	

THREE-ROW CYLINDRICAL ROLLER COMBINED SLEWING BEARING

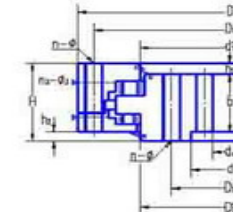
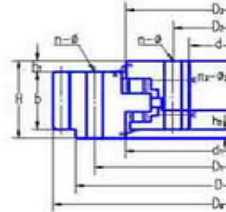
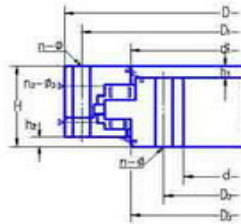

轴承型号 Designations			外形尺寸 Boundary dimensions			安装孔尺寸 Bolt hole diameter			结构尺寸 Structure dimensions					齿轮参数 Gear parameters					额定负荷 Basic load ratings		质量 Mass					
无齿式 non-gear type	外齿式 external gear type	内齿式 internal gear type	D	d	H	D1	D2	n	φ	D3 (D3')	d1 (d1')	h1	h2	n3	φ3	m	Da	Z	da	Z	b	x	Coa	Cor	10 ⁴ N	kg
130-50-3150-** 130-50-3150-12K	132-50-3150-**	134-50-3150-**	3432	2868	270	3342	2958	72	45	(3104)	(3087)	65	12	8×2	M10×1	22	3542	158	2750	126	180	+0.5	3590	381	5000	
			3432	2868	270	3342	2958	72	45	3103	3086	50	12	8×2	M10×1											3735
		131-30-3150-12K		3376	2922	182	3286	3014	56	45	3190	3180	40	10	8×3	M10×1	20	3476	171			120	+0.5	2050	202	2308
		131-50-3150-12K		3432	2868	270	3342	2958	72	45	3214	3197	50	12	8×2	ZG1/4in	20	3540	174			180	+0.5	3735	474	5404
		132-50-3150-12K		3432	2868	270	3342	2958	72	45	3214	3197	50	12	8×2	ZG1/4in	22	3542	158			180	+0.5	3735	474	5409
		132-50-3150-12K1		3432	2868	270	3342	2958	72	45	3214	3197	50	12	8×3	M10×1	20	3536	174			195	+0.5	3735	474	5385
			133-50-3150-11K	3432	2868	270	3342	2958	60	39	3103	3086	50	12	8×2	M10×1	20			2761	139	180	+0.5	3575	501	5174
			133-50-3150-12K	3432	2868	270	3342	2958	60	39	3103	3086	50	12	8×2	M10×1	20			2761	139	180	+0.5	3575	501	5174
			133-50-3150-12K1	3432	2868	270	3342	2958	60	39	3103	3086	50	12	8×2	M10×1	18			2754	154	180	+0.5	3575	501	5174
			134-50-3150-11K	3432	2868	270	3342	2958	72	45	3103	3086	50	12	6×2	ZG1/4in	22			2759	128	180	+0.5	3575	501	5104
130-50-3550-**	131-50-3550-**	133-50-3550-**	3832	3268	270	3742	3358	72	45	3613	3596	65	12	8×2	M10×1	20	3940	194	3160	159	180	+0.5	4040	431	5600	
			3832	3268	270	3742	3358	72	45	(3504)	(3487)	65	12	8×2	M10×1	22	3938	176	3146	144	180	+0.5	4040	431	5600	
		132-50-3550-03K		3832	3268	270	3742	3358	72	45	3613	3596	65	12	8×3	M10×1	22	3934	176			180	+0.5	4105	401	4960
		132-50-3550-12		3832	3268	270	3742	3358	72	45	3613	3596	65	12	8×3	M10×1	22	3938	176			180	+0.5	4105	401	5318
130-50-4000-**	131-50-4000-**	133-50-4000-**	4282	3718	270	4192	3808	80	45	4063	4046	65	12	8×2	M10×1	22	4400	197	3608	165	180	+0.5	4560	487	6400	
			4282	3718	270	4192	3808	80	45	3954	3937	65	12	8×2	M10×1	25	4400	173	3600	145	180	+0.5	4560	487	6400	
		131-50-4000-04K		4282	3718	270	4192	3808	80	45	4063	4046	65	12	8×2	M10×1	22	4400	197			180	+0.5	4502	450	6377
	132-50-4000-12		4282	3718	270	4192	3908	80	45	4063	4046	65	12	8×3	M10×1	25	4400	173			180	+0.5	4502	450	6377	
130-50-4500-40	131-50-4500-**	133-50-4500-**	4782	4218	270	4692	4308	80	45	4563	4546	65	12	8×2	M10×1	22	4906	220	4114	188	185	+0.5	5445	580	6942	
			4782	4218	270	4692	4308	80	45	(4454)	(4437)	65	12	8×2	M10×1	25	4906	193	4100	165	185	+0.5	5445	580		
		131-50-4500-04		4782	4218	270	4692	4308	80	45	4565	4546	60	12	8×3	M10×1	20	4880	242			185	+0.5	4900	507	7250
		132-50-4500-04		4782	4218	270	4692	4308	80	45	4565	4546	60	12	10×2	M14×1.5	25	4895	193			185	+0.5	4900	506	7333
		131-60-5000-04		5320	4670	320	5220	4766	100	45	5082	5062	65	18	10×3	M10×1	20	5440	270			220	+0.5	6834	955	11752